



RLD Flight Manual

RLD Vlieghandboek

~~C-DUNK~~

~~N908A~~

~~PH-TWS~~

Correspondence address
P.O. Box 575, 2130 AN Hoofddorp, The Netherlands

Caution

In accordance with the Civil Air Navigation Regulations (RTL), Article 98, this Flight Manual is issued by the Director-General of Civil Aviation of the Netherlands (Directeur-Generaal van de Rijksluchtvaartdienst -RLD). You are cautioned that no person may operate the aircraft to which this manual applies, except in accordance with the operating limitations contained in this manual. It is the responsibility of the aircraft owner or operator to ensure that the proper weight & balance data, loading schedule and -instructions are available, that this manual is complete and that all amendments prescribed or approved by the RLD are incorporated.

Registration:

Aircraft Model:

Reims/Cessna F172M

Serial Number:

1402

Type Specification:

DGAC Fiche de Navigabilité
No. 77

Operating Limitations, Performance Information and Operating Instructions contained in:

1. Reims Aviation's Aircraft Flight Manual for the 1976 Model F172M, code D1057, issued September 1972 and DGAC-approved November 05, 1973 including revision No. 6 (for the 1976 model) dated August 1975 and DGAC-approved November 05, 1975 and later DGAC-approved and applicable revisions.
2. All applicable Supplements and/or Amendments related to RLD-accepted optional systems and/or RLD-accepted modifications installed on the aircraft.

The Director-General of Civil Aviation of the Netherlands,

on behalf,



Issued: 22 March 1996.

This sheet supersedes the sheet dated: complete reissue.

PAGE	1	2							
dd-mm-yy	22-03-96	22-03-96							

RLD Flight Manual
RLD Vlieghandboek

Operations Sheet

Page 2

The authorized operations of this aircraft are defined by the category in which the aircraft is certificated and the installed and operative equipment. The operations are further defined by the Flight Operations Rules contained in Chapter V of the Civil Air Navigation Regulations (RTL). The owner/operator is reminded that the authorized operations only apply to the airspace of the Netherlands and that for operations outside this area, local regulations must be observed.

BASIC EQUIPMENT

- Altimeter
- Airspeed indicator
- Compass
- Engine instruments

ADDITIONAL REQUIREMENTS FOR SIGHTSEEING FLIGHTS

1. Fire extinguisher
2. During sightseeing flights the copilot's seat may not be occupied by a passenger, unless the flight controls are modified in an approved manner so that the occupant is not in a position to interfere with the pilot in controlling the aircraft.

ADDITIONAL REQUIREMENTS FOR INSTRUMENT FLIGHT RULES (IFR) OPERATIONS

3. Outside Air Temperature (OAT) indicator
4. Gyroscopic turn and bank indicator + slip indicator
5. Artificial horizon (power supply independent of item 4)
6. Directional gyroscope
7. Vacuum and/or voltage indicator (for 4, 5 and 6)
8. Heated pitot tube
9. Vertical speed indicator
10. Automatic Direction Finding (ADF)
11. VHF communication installation (primary set)
12. VHF communication installation (secondary set)
13. VHF navigation installation
14. Air Traffic Control (ATC) transponder
15. Altitude reporting
16. Distance Measuring Equipment (DME)

ADDITIONAL REQUIREMENTS FOR FLIGHT AT NIGHT

17. Instrument panel lighting
18. Navigation lighting and landing light installation
19. Passenger cabin lighting

ADDITIONAL EQUIPMENT FOR SECOND PILOT IF THE SECOND PILOT IS REQUIRED

20. Airspeed indicator
21. Altimeter
22. Vertical speed indicator
23. Directional gyroscope
24. Artificial horizon
25. Gyroscopic turn and bank indicator + slip indicator

NOTE: Item 25 is not required provided the second pilot's artificial horizon is powered independent of the pilot's gyroscopic turn and bank indicator + slip indicator.

AIRCRAFT

C-DUNK

FLIGHT MANUAL

REIMS/CESSNA F172M

THIS FLIGHT MANUAL IS ASSIGNED TO
THE AIRCRAFT REGISTERED



Manufacturer : REIMS AVIATION
Aérodrome de REIMS-PRUNAY
51 REIMS (FRANCE)

French Type Certificate No. 25

Serial Number :

Registration Number :

Sections : 2 - 3 - 5

Pages : 2-1 thru 2-6
3-1 thru 3-7
5-6, 5-7 and 5-11



This is the exact translation of the F172M French Flight Manual approved by SGAC on October 26, 1972.

This aircraft should be operated in accordance with the limits specified in this Flight Manual.

THIS DOCUMENT SHOULD BE CARRIED IN THE AIRCRAFT AT ALL TIMES.

Edition 1 - September 1972
Revision 6 - August 1975

Aircraft Serial No. 905 on

TABLE OF CONTENTS

SGAC Approved Cover Page	0-1
Table of Contents	0-2 and 0-3
List of Revised Pages	0-4 and 0-5
 <u>SECTION 1 - GENERAL</u>	
Documents Available	1-1
Principal Dimensions	1-2
Description and Characteristic Dimensions	1-3 thru 1-5
Instrument Panel	1-6 and 1-7
Fuel System	1-8 and 1-9
Oil Quick - Drain Valve	1-10
Electrical System	1-11 thru 1-15
Cabin Heating and Ventilating System	1-14
 <u>SECTION 2 - LIMITATIONS</u>	
Certification Basis	2-1
Airspeed Limitations	2-1 and 2-2
Approved Maneuvers	2-3
Engine Operation Limitations and Instrument Markings	2-3 and 2-4
Placards	2-5 and 2-6
 <u>SECTION 3 - EMERGENCY PROCEDURES</u>	
Engine Failure	3-1 and 3-2
Fires	3-2 and 3-3
Forced Landings	3-4
Ditching	3-4 and 3-5
Flight in Icing Conditions	3-5 and 3-6
Recovery From a Spiral Dive	3-6
Electrical System Failures	3-6 and 3-7
 <u>SECTION 4 - NORMAL PROCEDURES</u>	
Loading Graph and Center of Gravity Moment Envelope	4-1 thru 4-4
Exterior Inspection	4-5 thru 4-8
Before Flight and In-Flight Checks	4-9 thru 4-12
Operating Details	4-13 thru 4-20
Rough Engine Operation and Loss of Power	4-21 and 4-22
Specific Operation	4-23 and 4-24



SECTION 5 - PERFORMANCE

Performance - Specifications	5-1 thru 5-3
Cruise Performance	5-4 and 5-5
Airspeed Correction Table	5-6
Stall Speeds	5-7
Take-off Distance	5-8
Landing Distance	5-9
Maximum Rate of Climb Data	5-10
Maximum Glide	5-11



SECTION 6 - APPENDIX

Servicing	6-0.1 thru 6-0.4
Maintenance	6-0.5 thru 6-0.7
Optional Systems	6-1.0 and on

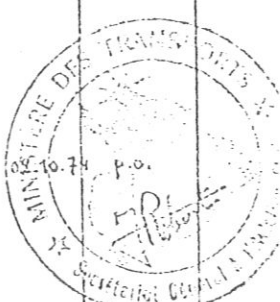
LIST OF REVISED PAGES

No.	Revised Pages	Nature of Change	Approval	
			Date	Visa
1	0-5 1-5 6-0.1	Use of 100L Aviation Fuel	7	
2	0-3, 0-4, 0-5 1-2, 1-5, 1-6, 1-7 1-10, 1-13 2-2, 2-5, 2-6 3-5 4-1 thru 4-22 5-2, 5-4, 5-5, 5-6 5-9, 5-10 6-0.1 thru 6-0.7 6-1.0, 6-1.1, 6-1.3 6-1.30	1974 Model beginning with Serial Number 1035		
3	0-4, 6-1.0 (cont'd) 6-1.52 thru 6-1.55	Nav-O-Matic 200A Automatic Pilot		

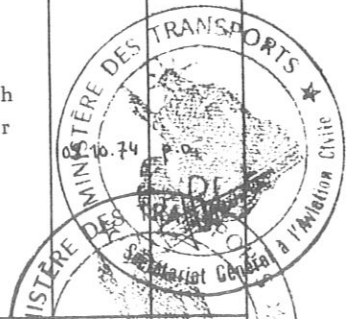
LIST OF REVISED PAGES

No.	Revised Pages	Nature of Change	Approval	
			Date	Visa
4	0-2, 0-5 1-5 thru 1-10 1-12 thru 1-15 2-5 3-1, 3-2, 3-4, 3-7 4-11, 4-18, 4-20 thru 4-24 5-10 6-0-3	1975 Model beginning with Serial Number 1235	05.10.74	
5	0-5 6-1.0 (cont'd) 6-1.56 thru 6-1.60	NAV-O-MAT 300A Automatic Pilot	05.11.75	
6	0-1, 0-5, 1-6 and 1-7, 1-12 thru 1-15, 2-1, 2-3, 2-5, 3-1 thru 3-7, 4-6, 4-10, 4-11, 4-15 thru 4-19, 4-23, 5-4 thru 5-11, 6-0.6 and 6-0.7, 6-1.0, 6-1.2 thru 6-1.7 6-1.8A and 6-1.8B 6-1.9 à 6-1.11, 6-1.13, 6-1.20, 6-1.25, 6-1.32 6-1.38, 6-1.40 and 6-1.41, 6-1.47 and 6-1.48	1976 Model beginning with Serial Number 1385	05.11.75	

GENERAL

NOTIFICATION

This manual contains the instructions for use, and the list of Servicing and periodic inspections, as well as the performance data of the Model REIMS/CESSNA F172M.

DOCUMENTS AVAILABLE

The following is a check list of the data, information and licenses that are part of the aircraft file and required by Regulations. They should be made available at all times to relevant Authority.

- (1) Airworthiness Certificate.
- (2) Registration Certificate.
- (3) Radio Installation License (if radio installed).
- (4) Log Books.
- (5) Flight Manual.

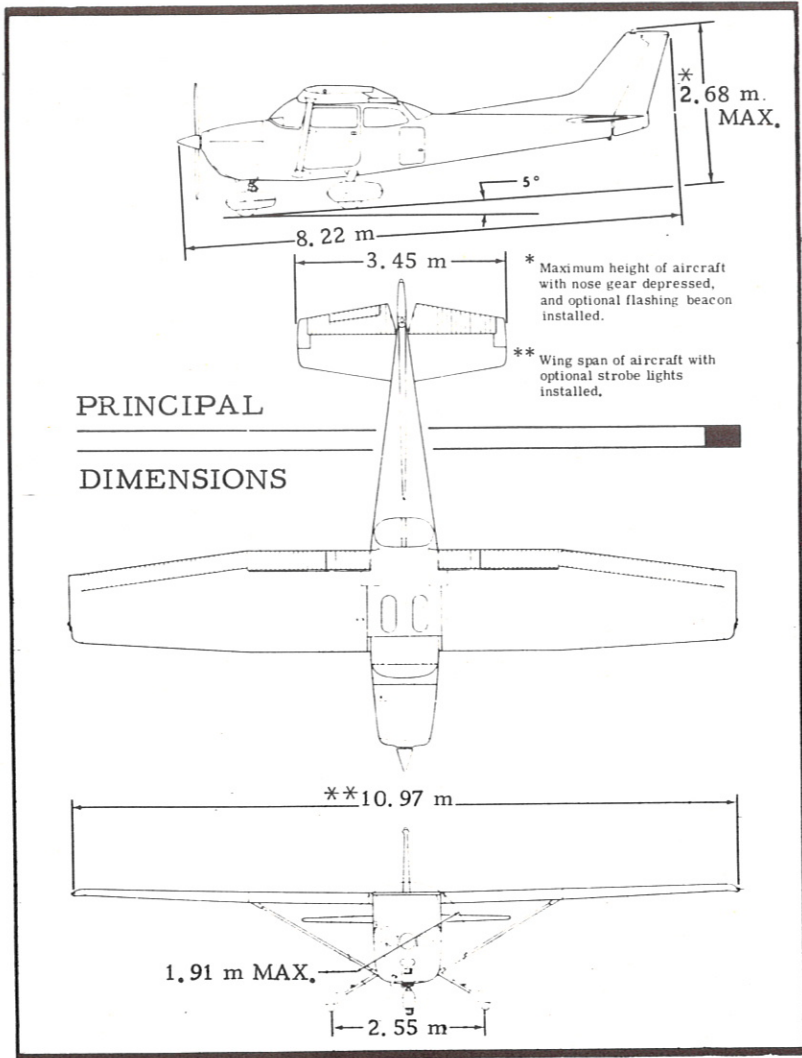

Figure 1

DESCRIPTION AND CHARACTERISTIC DIMENSIONS

Over-All Dimensions

Wing Span		10.97 m With Optional Strobe Lights
Maximum Length		8.22 m
Maximum Height		2.68 m With Flashing Beacon and Nose Strut Depressed

Wing

Airfoil Type		NACA2412 (Modified)
Wing Area		16.30 m ²
Dihedral Angle		+ 1°37' (at 25 % chord)
Angle of Incidence,	Wing Root	+ 0°47'
	Wing Tip	- 2°50'

Ailerons*

Area		1.66 m ²
Control Travel,	Up	20° ± 1°
	Down	15° ± 1°

Wing Flaps

Method of Actuation		Electric/Cable
Area		1.97 m ² + 0°
Control Travel		0° to 40° - 2°

Horizontal Stabilizer and Elevator*

Stabilizer Area		2.00 m ²
Angle of Incidence		- 3°30'

* Cable control systems

Elevator Area		1.35 m ² (including tab)
Control Travel,	Up	28° + 1° - 0°
	Down	23° + 1° - 0°

Elevator Trim Tab

Control Travel,	Up	28° + 1° - 0°
	Down	13° + 1° - 0°

Vertical Fin and Rudder*

Fin Area		1.26 m ²
Rudder Area		0.69 m ²
Control Travel, (parallel to a/c longitudinal axis)	Left	16° ± 1°
	Right	16° ± 1°

Landing Gear

Type		Fixed, Tricycle	
Shock Absorber,	Nose Gear	Air - Oil	
	Main Gear	Tubular Spring	
Tread		2.55 m	
Nose Wheel Tire and Pressure	5,00 x 5	2.14 bars	31 psi
Main Wheel Tire and Pressure	6,00 x 6	2.00 bars	29 psi
Nose Gear Shock Strut Pressure		3.10 bars	45 psi

* Cable control systems

Power Plant

Engine Lycoming O-320-E2D 150 HP (112 kW)
Fuel Aviation fuel, 80/87 Octane, Minimum Grade, or 100L,

NOTE

100/130 Aviation Grade Fuel with maximum lead content of 4.6 cc per gallon is also approved for use (Refer to Avco Lycoming Service Bulletin N° 1070F),

Oil SAE 10W30 or SAE 30 between - 20°C and + 20°C
(-4°F and + 68°F)
SAE 50 above + 15°C (+ 59°F)
SAE 40 between - 1°C and + 30°C (+ 30°F and + 86°F)
SAE 20 below - 10°C (+ 14°F)
Carburetor Heater Manually Operated

Propeller

Number McCauley 1C160/CTM7553 or 1C160/DTM7553
Type Fixed Pitch
Diameter 1.91 m

Cabin

Seating 4 (plus optional child seat)
Doors 2
Baggage compartment

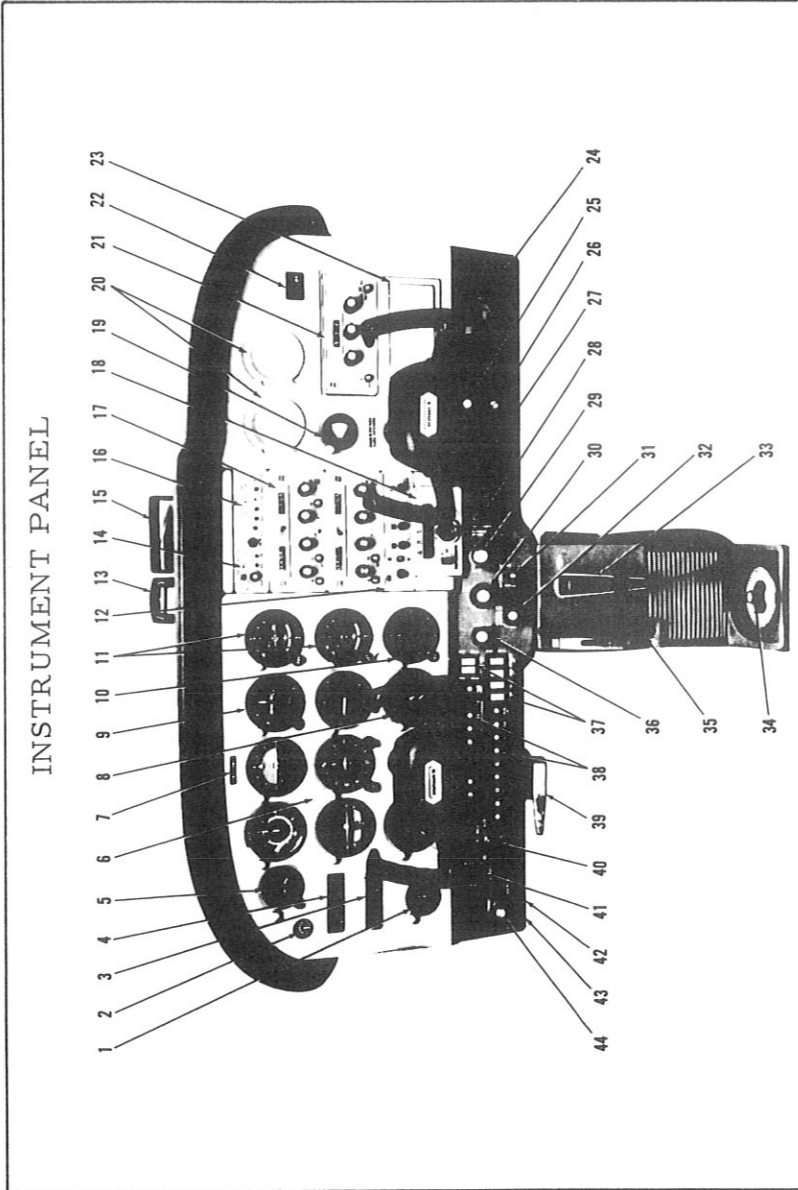

Figure 2

DESCRIPTION

- | | |
|----------------------------------------------------|--------------------------------------------------|
| 1. Ammeter | 23. Additional Radio Space |
| 2. Suction Gage | 24. Map Compartment |
| 3. Oil Temperature and
Oil Pressure Gages | 25. Cabin Heat Control Knob |
| 4. Left and Right Fuel Gages | 26. Cabin Air Control Knob |
| 5. Clock | 27. Cigar Lighter |
| 6. Flight Instrument Group | 28. Wing Flap Switch |
| 7. Airplane Registration Number | 29. Mixture Control Knob |
| 8. Secondary Altimeter | 30. Throttle |
| 9. Encoding Altimeter | 31. Alternate Static Source
Valve |
| 10. ADF Bearing Indicator | 32. Instrument and Radio Dial
Light Rheostats |
| 11. Omni Course Indicators | 33. Microphone |
| 12. Transponder | 34. Fuel Selector Valve Handle |
| 13. Magnetic Compass | 35. Elevator Trim Control Wheel |
| 14. Marker Beacon Indicator
Lights and Switches | 36. Carburetor Heat Control Knob |
| 15. Rear View Mirror | 37. Electrical Switches |
| 16. Radio Selector Switches | 38. Circuit Breakers |
| 17. Radios | 39. Parking Brake Handle |
| 18. Autopilot Control Unit | 40. Ignition Switch |
| 19. Wing Flap Position Indicator | 41. Master Switch |
| 20. Additional Instrument Space | 42. Auxiliary Mike Jack |
| 21. ADF | 43. Phone Jack |
| 22. Flight Hour Recorder | 44. Primer |

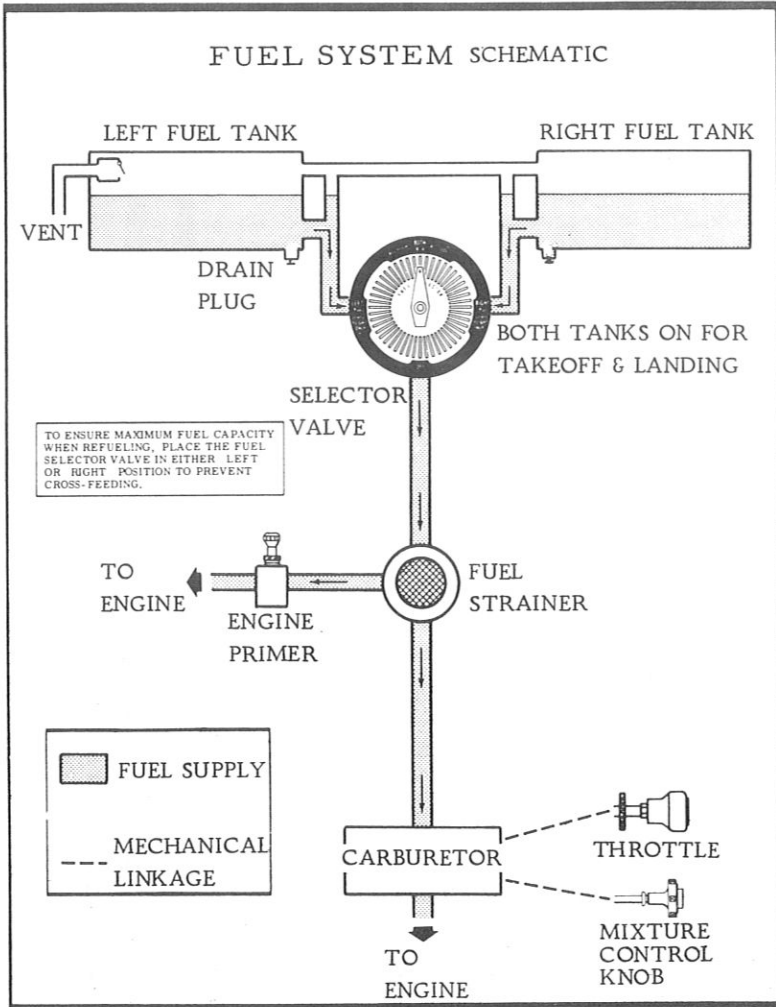

Figure 3

FUEL SYSTEM

Fuel is supplied to the engine from two tanks, one in each wing. From these tanks, fuel flows by gravity to a four-position selector valve labeled "RIGHT", "BOTH", "LEFT" and "OFF" and through a fuel strainer to the carburetor.

For additional information on Lubrication and Servicing, refer to the maintenance guide of this aircraft.

FUEL TANK SUMP QUICK-DRAIN VALVES

Each fuel tank sump is equipped with a fuel quick-drain valve which extends through the lower surface of the wing just outboard of the cabin door. A sampler cup stored in the aircraft is used to examine the fuel for the presence of water and sediment. A "STRAINER DRAIN KNOB" is located inside the engine nose cap access door and is connected to the strainer quick-drain valve. After the knob has been released, make sure that strainer drain is closed.

FUEL QUANTITY DATA			
TANKS	USABLE FUEL ALL FLIGHT CONDITIONS	UNUSABLE FUEL	TOTAL FUEL VOLUME
TWO, STANDARD WING 79.5 litres each	144 litres	15 litres	159 litres

NOTE : The aircraft may be fitted with two optional 98.5 litres (26 US Gal.) wing tanks (each) (91 litres - 24 US Gal. usable) instead of the above two standard tanks.

OIL QUICK-DRAIN VALVE (Option)

An oil quick-drain valve is optionally offered to replace the drain plug in the oil sump drain port. The valve provides a quicker and cleaner method of draining engine oil. To drain the oil with this valve installed, slip a hose over the end of the valve, route the hose to a suitable container, then push upward on the end of the valve until it snaps into the open position. Spring clips will hold the valve open. After draining, use a screwdriver or suitable tool to snap the valve into the extended (closed) position and remove the drain hose.

ELECTRICAL SYSTEM

Electrical energy is supplied by a 14-volt engine-driven alternator. A 12-volt battery is located on the left-hand forward portion of the firewall adjacent to the engine access door.

On the Reims Aviation aircraft model, power is supplied to all electrical circuits through a split bus bar, one side containing electronic systems and the other side having general electrical systems. Both sides of the bus are on at all times except when either an external power source is connected or the ignition/starter switch is turned on ; then a power contactor is automatically activated to open the circuit to the electronic bus. Isolating the electronic circuits in this manner prevents harmful transient voltages from damaging the transistors in the electronic equipment.

The bus bar distribution principle is illustrated in the electrical system schematic.

MASTER SWITCH

The master switch is a split-rocker type switch labeled "MASTER", and is "ON" in the up position and "OFF" in the down position. The right half of the switch, labeled "BAT", controls all electrical power to the airplane. The left half, labeled "ALT", controls the alternator.

Normally, both sides of the master switch should be used simultaneously, however, the "BAT" side of the switch could be turned "ON" separately to check equipment while on the ground. The "ALT" side of the switch, when placed in the "OFF" position, removes the alternator from the electrical system. With this switch in the "OFF" position, the entire electrical load is placed on the battery. Continued operation with the alternator switch "OFF" will reduce battery power low enough to open the battery contactor, remove power from the alternator field, and prevent alternator restart.

AMMETER

The ammeter indicates the flow of current, in amperes, from the alternator to the battery or from the battery to the aircraft electrical

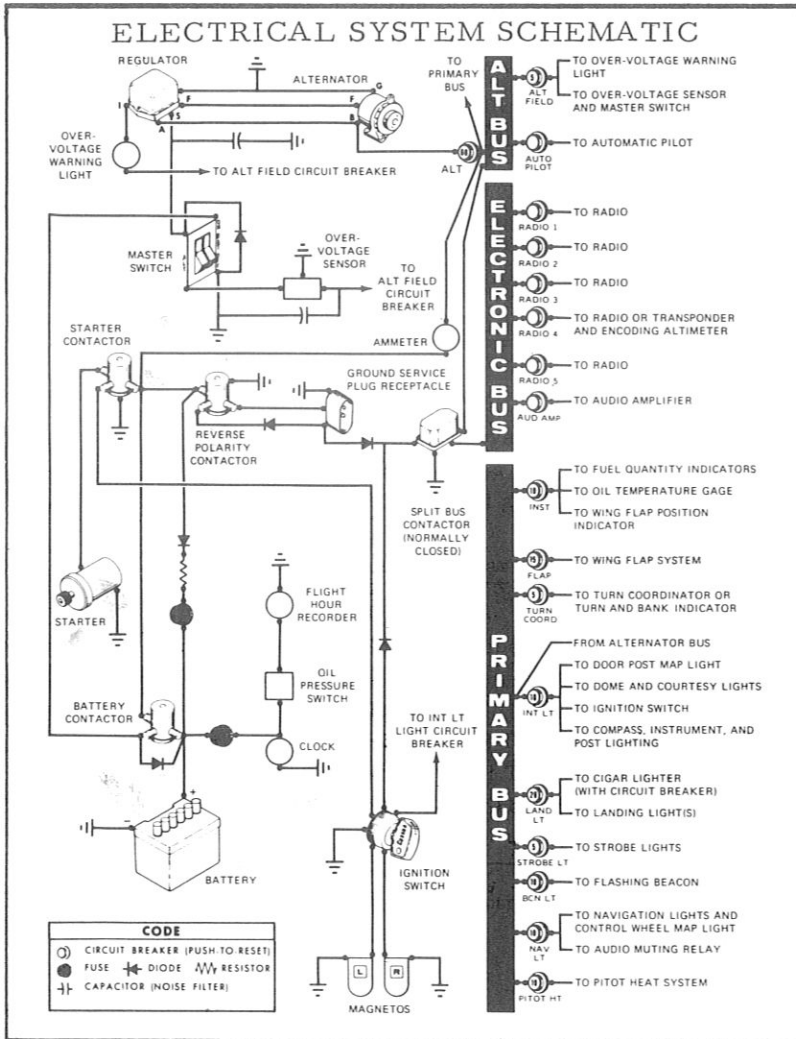

Figure 4

system. When the engine is operating and the master switch is "ON", the ammeter indicates the charging rate applied to the battery or the discharge rate if the alternator is not functioning.

OVER-VOLTAGE SENSOR AND WARNING LIGHT

The aircraft is equipped with an automatic over-voltage protection system consisting of an over-voltage sensor behind the instrument panel and a red warning light, labeled "HIGH VOLTAGE". In the event an over-voltage condition occurs, the over-voltage sensor automatically removes alternator field current and shuts down the alternator. The red warning light will then turn on, indicating to the pilot that the aircraft battery is supplying all electrical power.

The over-voltage sensor may be reset by turning the master switch off and back on again. If the light does illuminate again, a malfunction has occurred and the flight should be terminated as soon as practical.

The over-voltage warning light may be tested by momentarily turning off the "ALT" portion of the master switch and leaving the "BAT" portion turned on.

CIRCUIT BREAKERS AND FUSES

Most of the electrical circuits in the airplane are protected by "push-to-reset" circuit breakers mounted on the right side of the instrument panel. Exceptions to this are the battery contactor closing (external power) circuit, clock, and flight hour recorder circuits which have fuses mounted near the battery. The control wheel map light is protected by the "NAV LT" circuit breaker on the instrument panel, and as fuse behind the panel. The cigar lighter is equipped with a manually reset circuit breaker, on the back of the lighter, and is also protected by the "LAND LT" circuit breaker.

LANDING AND TAXI LIGHTS (OPT)

Optional lighting includes a single landing light or dual landing/taxi lights in the cowl nose cap, controlled by a switch.

FLASHING BEACON AND HIGH INTENSITY STROBE LIGHTS (OPT)

These lights should not be used when flying through clouds or overcast ; the flashing light reflected from water droplets or particles in the atmosphere, particularly at night, can produce vertigo and loss of orientation. In addition, the two high intensity strobe lights should be turned off when taxiing in the vicinity of other aircraft.

CABIN HEATING AND VENTILATING SYSTEM

Control of heated and fresh air into the cabin is provided by manipulation of the "CABIN HT" and "CABIN AIR" push-pull knobs which also provide for windshield defrost air supply.

Cabin heating is provided by actuation of the "CABIN HT" knob by pulling it approximately 1 cm (1/2 in.) for a moderate amount of cabin heat. If maximum heat is desired, pull the knob fully out.

Front cabin heat is supplied by outlet holes spaced just forward and above the rudder pedal assembly. Rear cabin heat is supplied by two ducts, one on each side of the cabin at floor level.

Windshield defrost air is also controlled by the same control.

Cabin ventilating air is controlled by the "CABIN AIR" knob.

Separate adjustable ventilators supply additional air ; one near each upper corner of the windshield supplies air for the pilot and copilot.

Two optional ventilators supply air for the rear seat passengers.

PARKING BRAKE SYSTEM

To set parking brake, pull out the handle below the pilot's side instrument panel and lock it in the detents by turning it 1/4 turn downwards. To release the parking brake, unlock the handle and push it fully in.

CONTROL WHEEL MAP LIGHT (OPT)

An optional map light may be mounted on the bottom of the pilot's control wheel. The light illuminates the lower portion of the cabin, just forward of the pilot and is helpful when checking maps and other flight data during night operations. To operate the light, first turn on the "NAV LTS" switch, then adjust the map light's intensity with the disk type rheostat control located on the bottom of the control wheel.

STALL WARNING HORN

The stall warning horn produces a steady signal 9 to 18 km/h - 5 to 10 kts - 6 to 12 MPH before actual stall is reached and remains on up to the stall.

LIMITATIONS

CERTIFICATION BASIS

The REIMS/CESSNA F172M is certified in the Normal and Utility Category under AIR 2052 regulations, with amendments dated 16 September 1966, with the limits indicated in this section.

INDICATED AIRSPEED LIMITATIONS

	km/h	kts	mph
Vne (Never Exceed Speed)	295	159	183
Vno (Maximum Structural Cruising Speed)	237	128	147
Vfe (Maximum Speed, Flaps Extended)	158	85	98
Vp (Maneuvering Speed)	180	97	112

AIRSPEED INDICATOR MARKINGS

Red line	295	159	183
Yellow Arc (Caution Range)	237-295	128-159	147-183
Green Arc (Normal Operating Range)	87-237	47-128	54-147
White Arc (Flap Operating Range)	78-158	42-85	48-98

FLIGHT MANEUVERING LOAD FACTORS AT GROSS WEIGHT

Normal Category : 1043 kg

Flaps Up	+3.8	-1.52
Flaps Down	+3.0	

Utility Category : 910 kg

Flaps Up	+4.4	-1.76
Flaps Down	+3.0	

MAXIMUM GROSS WEIGHT FOR TAKE-OFF AND LANDING

Normal Category : 1043 kg

Utility Category : 910 kg

CENTER OF GRAVITY LOCATION

Leveling Means : Upper door sill.

Center of Gravity Reference : Forward face of firewall.

Center of Gravity Range Limits :

NORMAL CATEGORY

Forward Limit	Rear Limit
+0.98 m at 1043 kg	+1.20 m
+0.89 m at 885 kg or less	

UTILITY CATEGORY

+0.90 m at 910 kg	+1.03 m
+0.89 m at 885 kg or less	

LOADING LIMITS

Number of Occupants : Front Seats : 2
Rear Seats : 2

Minimum Crew : 1

Maximum Baggage in Baggage Compartment Area 1 + Area 2 : 54 kg

Occupied Optional Child's Seat Approved if Fitted With a Safety Belt

AUTHORIZED OPERATIONS

If equipped with good condition instruments described in the approved appendix of this manual, this aircraft is certified for day, night, VFR and IFR flight operations.

MANEUVERS - UTILITY CATEGORY

This airplane is not designed for aerobatic maneuvers. However, certain maneuvers that are required in the acquisition of various certificates may be performed provided the limitations in the following table are not exceeded.

No aerobatic maneuvers are approved except those listed below :

<u>MANEUVER</u>	<u>RECOMMENDED ENTRY INDICATED SPEED</u>		
	km/h	kts	mph
Chandelles	195	105	120
Lazy Eights	195	105	120
Steep Turns	176	95	109
Spins	Use Slow Deceleration		
Stalls	Use Slow Deceleration		

Intentional spins with flaps extended are not approved. Inverted flight maneuvers are not recommended.

The important thing to bear in mind in flight maneuvers is that the airplane is clean in aerodynamic design and will build up speed quickly with the nose down. Proper speed control is an essential requirement for execution of any maneuver, and care should be exercised to avoid excessive speed which in turn can impose excessive loads. In the execution of all maneuvers, avoid abrupt use of controls.

ENGINE OPERATION LIMITATIONS

Power and Speed 112 KW (150 HP) at 2700 RPM

ENGINE INSTRUMENT MARKINGS

OIL TEMPERATURE GAGE

Normal Operating Range Green Arc
Maximum Allowable 118°C (245°F) red line

OIL PRESSURE GAGE

Minimum Idling 25 psi (1.72 bars) (red line)
Normal Operating 60-90 psi (4.13 - 6.20 bars) (green arc)
Maximum 100 psi (6.89 bars) (red line)

FUEL QUANTITY INDICATORS

Empty E (red line)
(7.50 litres unusable each tank)

TACHOMETER

Normal Operating Range

At sea level	2200-2500 RPM (inner green arc)
At 1524 m - 5000 feet	2200-2600 RPM (middle green arc)
At 3048 m - 10,000 feet	2200-2700 RPM (outer green arc)
Maximum Allowable	2700 RPM (red line)

FLIGHT IN ICING CONDITIONS

Flight in icing conditions is strictly prohibited.

PLACARDS

The following information is displayed in the form of individual placards.

- (1) In full view of the pilot :

<p>This airplane must be operated in compliance with the operating limitations as stated in the form of placards, markings, and manuals.</p>																					
<p>_____ MAXIMUMS _____</p>																					
	<table border="0"> <tr> <td style="text-align: center;"><u>Normal Category</u></td> <td style="text-align: center;"><u>Utility Category</u></td> </tr> </table>	<u>Normal Category</u>	<u>Utility Category</u>																		
<u>Normal Category</u>	<u>Utility Category</u>																				
MANEUVERING SPEED (IAS)	180 km/h - 97 kts - 112 MPH 180 km/h - 97 kts - 112 MPH																				
GROSS WEIGHT	2300 lbs - 1043 kg 2000 lbs - 910 kg																				
FLIGHT LOAD FACTOR	Flaps Up +3.8, -1.52																				
	Flaps Down +3.0 +3.0																				
<p>Normal Category - No acrobatic maneuvers including spins approved. Utility Category - Baggage compartment and rear seat must not be occupied.</p>																					
<p>NO ACROBATIC MANEUVERS APPROVED EXCEPT THOSE LISTED BELOW</p>																					
<table border="0"> <tr> <td style="text-align: center;">Recommended</td> <td style="text-align: center;">Recommended</td> </tr> <tr> <td style="text-align: center;"><u>Maneuver</u></td> <td style="text-align: center;"><u>Entry Speed (IAS)</u></td> </tr> <tr> <td>Chandelles</td> <td>195 km/h - 105 kts - 121 MPH Spins</td> </tr> <tr> <td>Lazy Eights</td> <td>195 km/h - 105 kts - 121 MPH Stalls (Except</td> </tr> <tr> <td>Steep Turns</td> <td>176 km/h - 95 kts - 109 MPH Whip Stalls)</td> </tr> <tr> <td colspan="2">Altitude loss in stall recovery : 180 ft - 55 m.</td> </tr> <tr> <td colspan="2">Abrupt use of the controls prohibited above 180 km/h - 97 kts - 112 MPH</td> </tr> <tr> <td colspan="2">Spin Recovery : opposite rudder - forward elevator - neutralize controls.</td> </tr> <tr> <td colspan="2">Intentional spins with flaps extended are prohibited. Flight into known icing conditions prohibited. This airplane is certified, depending on the equipment items installed, for the following flight operations as of date of original airworthiness certificate :</td> </tr> <tr> <td colspan="2" style="text-align: center;"> <p>DAY - NIGHT - VFR - IFR</p> </td> </tr> </table>		Recommended	Recommended	<u>Maneuver</u>	<u>Entry Speed (IAS)</u>	Chandelles	195 km/h - 105 kts - 121 MPH Spins	Lazy Eights	195 km/h - 105 kts - 121 MPH Stalls (Except	Steep Turns	176 km/h - 95 kts - 109 MPH Whip Stalls)	Altitude loss in stall recovery : 180 ft - 55 m.		Abrupt use of the controls prohibited above 180 km/h - 97 kts - 112 MPH		Spin Recovery : opposite rudder - forward elevator - neutralize controls.		Intentional spins with flaps extended are prohibited. Flight into known icing conditions prohibited. This airplane is certified, depending on the equipment items installed, for the following flight operations as of date of original airworthiness certificate :		<p>DAY - NIGHT - VFR - IFR</p>	
Recommended	Recommended																				
<u>Maneuver</u>	<u>Entry Speed (IAS)</u>																				
Chandelles	195 km/h - 105 kts - 121 MPH Spins																				
Lazy Eights	195 km/h - 105 kts - 121 MPH Stalls (Except																				
Steep Turns	176 km/h - 95 kts - 109 MPH Whip Stalls)																				
Altitude loss in stall recovery : 180 ft - 55 m.																					
Abrupt use of the controls prohibited above 180 km/h - 97 kts - 112 MPH																					
Spin Recovery : opposite rudder - forward elevator - neutralize controls.																					
Intentional spins with flaps extended are prohibited. Flight into known icing conditions prohibited. This airplane is certified, depending on the equipment items installed, for the following flight operations as of date of original airworthiness certificate :																					
<p>DAY - NIGHT - VFR - IFR</p>																					

- (2) Adjacent to fuel selector valve :

Both tanks on for takeoff and landing.

- (3) On the fuel selector valve :

"BOTH" - 38 Gal. - 144 l (all flight attitudes)
"LEFT" - 19 Gal. - 72 l (level flight only)
"RIGHT" - 19 Gal. - 72 l (level flight only)

- (4) Near flap indicator :

Avoid slips with flaps extended.

- (5) In baggage compartment :

- 120 lbs - 54 kg maximum baggage and/or auxiliary seat passenger forward of baggage door latch.
- 50 lbs - 23 kg maximum baggage aft of baggage door latch.
Maximum combined : 120 lbs - 54 kg.
- For additional loading instructions see weight and balance data.

U
R
G
E
N
C
E
I
I



EMERGENCY PROCEDURES

ENGINE FAILURE

DURING TAKE-OFF

- (a) Throttle - Idle.
- (b) Apply brakes.
- (c) Flaps - Retract.
- (d) Mixture - Idle cut-off.
- (e) Ignition Switch - "OFF".
- (f) Master Switch - "OFF".

AFTER TAKE-OFF

- (a) Glide Speed (IAS) - 121 km/h - 65 kts - 75 MPH (Flaps UP)
111 km/h - 60 kts - 69 MPH (Flaps DOWN)
- (b) Mixture - Idle cut-off.
- (c) Fuel Selector Valve Handle - "OFF".
- (d) Ignition Switch - "OFF".
- (e) Wing Flaps - As required (40° recommended).
- (f) Master Switch - "OFF".

CAUTION

Perform the landing straight ahead, making only small changes in heading to avoid obstructions. Never attempt to turn back to the landing strip.

DURING FLIGHT

- (a) Glide Speed (IAS) - 129 km/h - 70 kts - 80 MPH.
- (b) Fuel - Fuel Selector Valve Handle - "BOTH".
- (c) Mixture - Rich.
- (d) Throttle - Cracked one inch (2.5 cm).
- (e) Ignition Switch - "BOTH".

If the engine will not start, select an unobstructed area to land in and secure the engine as follows :

- (a) Mixture - Idle cut-off.
- (b) Throttle - Closed.
- (c) Ignition Switch - "OFF".

- (d) Fuel Selector Valve Handle - "OFF".
- (e) Leave master switch "ON" so that wing flaps can be extended.

NOTE

Full flaps are recommended for emergency landings on unpaved surfaces.

FIRES

ENGINE FIRE ON GROUND

In case of fire in the intake duct during ground operations, proceed as follows :

- (a) Starter - Crank.
- (b) Mixture - Idle cut-off.
- (c) Throttle - Full open.
- (d) Fuel Selector Valve Handle - "OFF".

NOTE

If fire occurs in intake duct during engine run-up, keep engine running for about 15 to 30 seconds. If fire persists, perform above steps (b), (c) and (d).

ENGINE FIRE IN FLIGHT

- (a) Cabin Heat Control - "CLOSED".
- (b) Mixture - Idle cut-off.
- (c) Throttle - Forward maximum.
- (d) Fuel Shutoff Valve Handle - "OFF".
- (e) Ignition Switch - "OFF".
- (f) Indicated Airspeed - 185 km/h - 100 kts - 115 MPH. If fire is not extinguished, increase glide speed to find an indicated airspeed which will provide an incombustible mixture.
- (g) Wing Flaps - As required (40° recommended).
- (h) Master Switch - "OFF".

NOTE

Do not attempt to restart the engine. Execute a forced landing.

CABIN FIRE

- (a) Master Switch - "OFF".
- (b) Cabin Heating and Ventilation Controls - Closed.

NOTE

Use a portable extinguisher if available.

WING FIRE

- (a) Master Switch - "OFF".
- (b) Ventilating Controls - Closed.

NOTE

Perform a sideslip on the side opposite to the wing in fire in an attempt to extinguish the flames. Land the aircraft as soon as possible with flaps retracted.

ELECTRICAL FIRE

- (a) Master Switch - "OFF".
- (b) All other switches - "OFF".
- (c) Master Switch - "ON".

NOTE

Select switches "ON" successively, permitting a short time delay to elapse after each switch is turned on until the short circuit is localized.

LANDING

LANDING WITH ONE FLAT TIRE

Lower the flaps normally and land the airplane with nose up and wing tilted to hold the flat tire off the ground as long as possible. At touch-down, use rudder and the brake on the good wheel to maintain directional control, and shut down the engine.

LANDING WITHOUT PITCH CONTROL

Trim for horizontal flight (with an indicated airspeed of approximately 111 km/h - 60 kts - 69 MPH and flaps lowerer to 20°) by using throttle and elevator trim controls. Then do not change this elevator trim setting, control the glide angle by adjusting power exclusively. At flareout, the nose-down moment resulting from power reduction is an adverse factor and the aircraft may hit on the nose wheel.

Consequently, at flareout, the control should be set at the full nose-up position and the power adjusted so that the aircraft will rotate to the horizontal attitude for touchdown. Close the throttle at touchdown.

FORCED LANDINGS

PRECAUTIONARY LANDING WITH ENGINE POWER

- (1) Drag over selected field with flaps 20° and 111 km/h - 60 kts - 69 MPH IAS.
- (2) Seat belts - Adjust and lock.
- (3) Turn off all switches except the ignition and master switches.
- (4) Approach with flaps 40° at 111 km/h - 60 kts - 69 MPH IAS.
- (5) Master Switch - "OFF".
- (6) Unlatch cabin doors.
- (7) Land in a slightly tail-low attitude.
- (8) Ignition Switch - "OFF".
- (9) Turn fuel shutoff valve to "OFF".
- (10) Apply heavy braking.

EMERGENCY LANDING WITHOUT ENGINE POWER

- (1) Pull mixture control to idle cut-off position.
- (2) Turn fuel selector valve to "OFF".
- (3) Turn all switches "OFF" except master switch.
- (4) Approach at 111 km/h - 60 kts - 69 MPH (flaps DOWN) IAS
121 km/h - 65 kts - 75 MPH (flaps UP) IAS
- (5) Extend wing flaps as required (40° recommended).
- (6) Turn master switch "OFF".
- (7) Unlatch cabin doors.
- (8) Land in a slightly tail-low attitude.
- (9) Apply heavy braking.

DITCHING

- (1) Prepare for ditching by securing or jettisoning heavy objects.
- (2) Transmit Mayday message on 121.5 MHz.
- (3) Plan approach into wind if winds are high and seas are heavy. With heavy swells and light wind, land parallel to swells.

- (4) Approach in level attitude with flaps 20° to 40° and sufficient power for a 300 ft./min. rate of descent at 102 km/h - 55 kts - 63 MPH (IAS). If no power is available, approach at 121 km/h - 65 kts - 75 MPH (IAS) and flaps up or 111 km/h - 60 kts - 69 MPH (IAS) with 10° flaps.
- (5) Unlatch the cabin doors.
- (6) Maintain a continuous descent until touchdown in level attitude.
- (7) Place folded coat or cushion in front of face at time of touchdown.
- (8) Evacuate airplane through cabin doors. If necessary, open window to flood cabin compartment for equalizing pressure so that door can be opened.
- (9) Inflate life vests and raft (if available) after evacuation of cabin. The aircraft can not be depended on for floatation for more than a few minutes.

FLIGHT IN ICING CONDITIONS

Although flying in known icing conditions is prohibited, an unexpected icing encounter should be handled as follows :

- (1) Turn pitot heat switch "ON".
- (2) Turn back or change altitude to obtain an outside air temperature that is less conducive to icing.
- (3) Pull cabin heat control full out and adjust windshield defroster airflow and cabin fresh air flow using the controls. Increase heated air flow by closing the cabin air control.
- (4) Open the throttle to increase engine speed to minimize ice buildup.
- (5) Apply carburetor heat.
- (6) Plan a landing at the nearest airport.
- (7) With an important ice accumulation, be prepared for significantly higher stall speed.
- (8) Leave wing flaps retracted since wing flap extension could result in a loss of elevator effectiveness.
- (9) Open left window and, if practical, scrape ice from a portion of the windshield for visibility in the landing approach.
- (10) Perform a landing approach using a forward slip, if necessary, for improved visibility.
- (11) Approach at 121 to 137 km/h - 65 to 74 kts - 75 to 85 MPH, (IAS), depending upon the amount of ice accumulation.

- (12) Avoid sharp bank in the landing approach.
- (13) Perform a landing in level attitude.

INADVERTENT SPIN (NORMAL CATEGORY)

To recover from an inadvertent spin, use the following standard procedure :

- (1) Retard throttle to idle position and neutralize ailerons.
- (2) Apply full rudder opposite to the direction of rotation.
- (3) After one-fourth turn, move the control wheel forward of neutral in a brisk motion.
- (4) As the rotation stops, neutralize the rudder, and make a smooth recovery from the resulting dive.

RECOVERY FROM A SPIRAL DIVE

If a spiral is encountered, proceed as follows :

- (1) Close the throttle.
- (2) Stop the turn by using coordinated aileron and rudder control to align the symbolic airplane in the turn coordinator with the horizon reference line.
- (3) Cautiously apply elevator back pressure to slowly reduce the indicated airspeed to 148 km/h - 80 kts - 92 MPH.
- (4) Adjust the elevator trim control to maintain a 148 km/h - 80 kts - 92 MPH IAS glide.
- (5) Keep hands off the control wheel, using rudder control to hold a straight heading.
- (6) Apply carburetor heat.
- (7) Upon breaking out of clouds, apply normal cruising power and resume flight.

ELECTRICAL SYSTEM FAILURES

COMPLETE ELECTRICAL FAILURE

A complete electrical failure causes the loss of the turn coordinator, the fuel quantity indicators and the wing flaps.

Turn the master switch to "OFF" and land as soon as possible.

ALTERNATOR OR VOLTAGE REGULATOR FAILURE

The battery keeps supplying the aircraft electrical system.

Turn to "OFF" all equipment that is not essential for flight.

If applicable, wait 2 to 3 minutes and reset the alternator circuit-breaker. In case it pops out again, do not insist and land as soon as possible.

ELECTRICAL POWER SUPPLY SYSTEM MALFUNCTIONS

Malfunctions in the electrical power supply system can be detected by periodic monitoring of the ammeter and over-voltage warning light.

If the ammeter indicates a continuous discharge rate in flight, turn the alternator switch to "OFF" and land as soon as possible.

If the charging rate were to remain above the normal value, the over-voltage sensor will automatically shut down the alternator and the over-voltage warning light will illuminate. Turn the master switch off and then on again. If the light comes on again, the flight should be terminated as soon as practical.

If the emergency occurs at night, turn the alternator switch back on for use of the landing light and flaps.

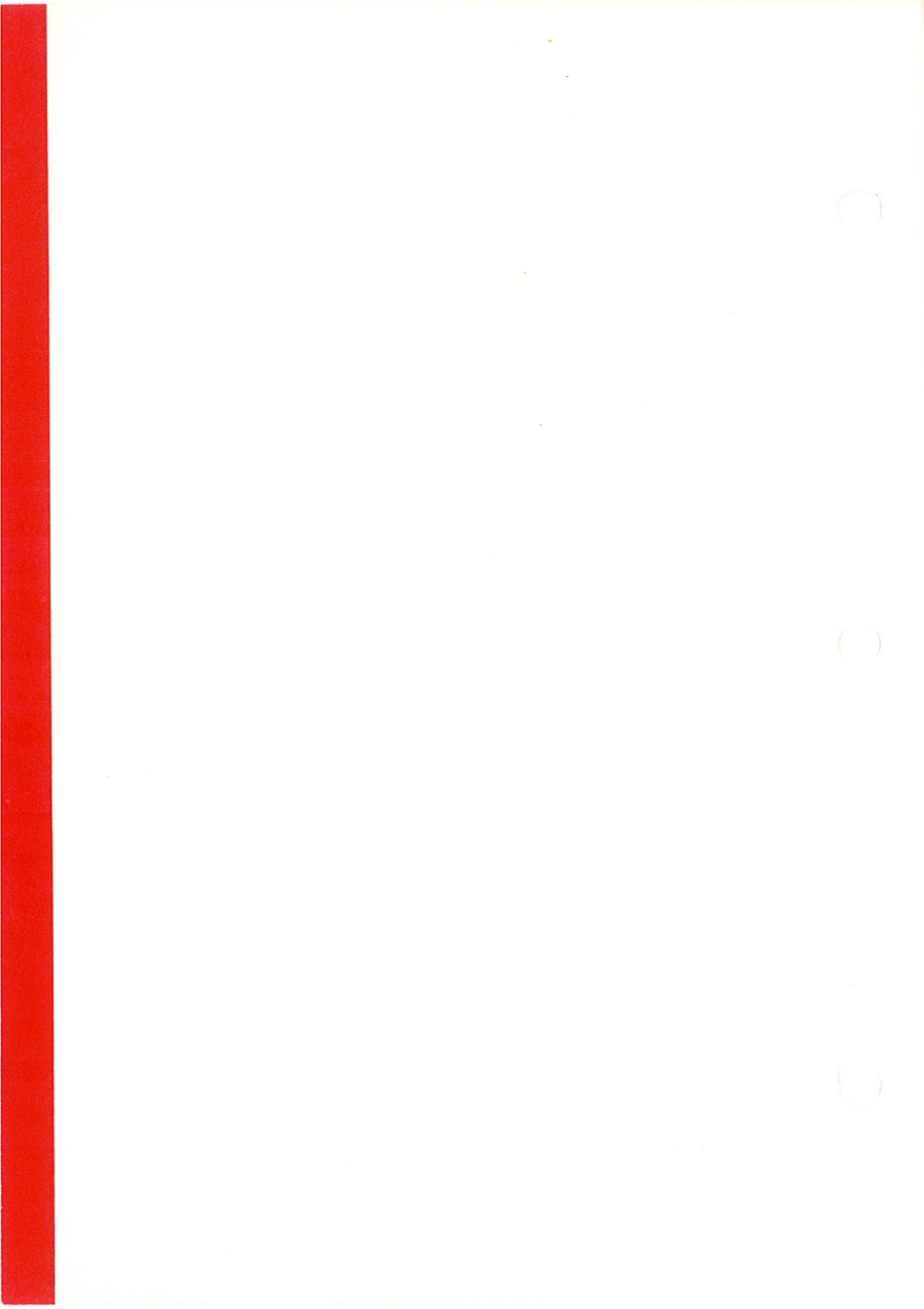

Flight Manual
REIMS/CESSNA F172M

Edition No. 1
September 1972
Revision No. 2
August 1973

LOADING GRAPH AND
CENTER OF GRAVITY MOMENT ENVELOPE

SAMPLE LOADING PROBLEM NORMAL CATEGORY	SAMPLE AIRPLANE		YOUR AIRPLANE	
	Weight kg	Moment m.kg	Weight kg	Moment m.kg
Licensed Empty Weight	618	595		
Oil * 7.6 litres	6.8	- 2	6.8	- 2
Fuel (Standard - 144 litres at 0.72 kg/litre)	103	126		
Fuel (Long Range - 182 litres at 0.72 kg/litre)				
Pilot and Front Passenger (Station 0.86 to 1.17 m)	154	145		
Rear Passengers	154	285		
** Baggage - Area 1 : 54 kg Max. (Station 2.08 to 2.74 m) or Passenger on Child's Seat	7.2	17		
** Baggage - Area 2 : 23 kg Max. (Station 2.74 to 3.61 m)				
TOTAL WEIGHT AND MOMENT	1043	1166		

Locate this point (1043 and 1166) on the center of gravity moment envelope, and since this point falls within the envelope, the loading is acceptable.
* Full oil may be assumed for all flights
**Maximum Combined Weight - Area 1 + Area 2 : 54 kg

SAMPLE LOADING PROBLEM UTILITY CATEGORY	SAMPLE AIRPLANE		YOUR AIRPLANE	
	Weight kg	Moment m.kg	Weight kg	Moment m.kg
Licensed Empty Weight	618	595		
Oil * 7.6 litres	6.8	-2	6.8	-2
Fuel (Standard - 144 litres at 0.72 kg/litre)	103	126		
Fuel (Long Range - 182 litres at 0.72 kg/litre)				
Pilot and Front Passenger (Station 0.86 to 1.17 m)	154	145		
TOTAL WEIGHT AND MOMENT	881.8	864		

Locate this point (881.8 and 864) on the center of gravity moment envelope, and since this point falls within the envelope, the loading is acceptable.
* Full oil may be assumed for all flights.

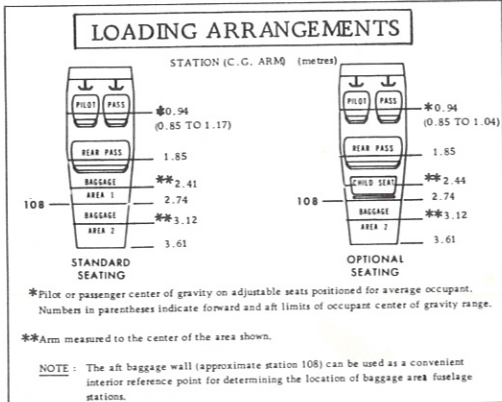

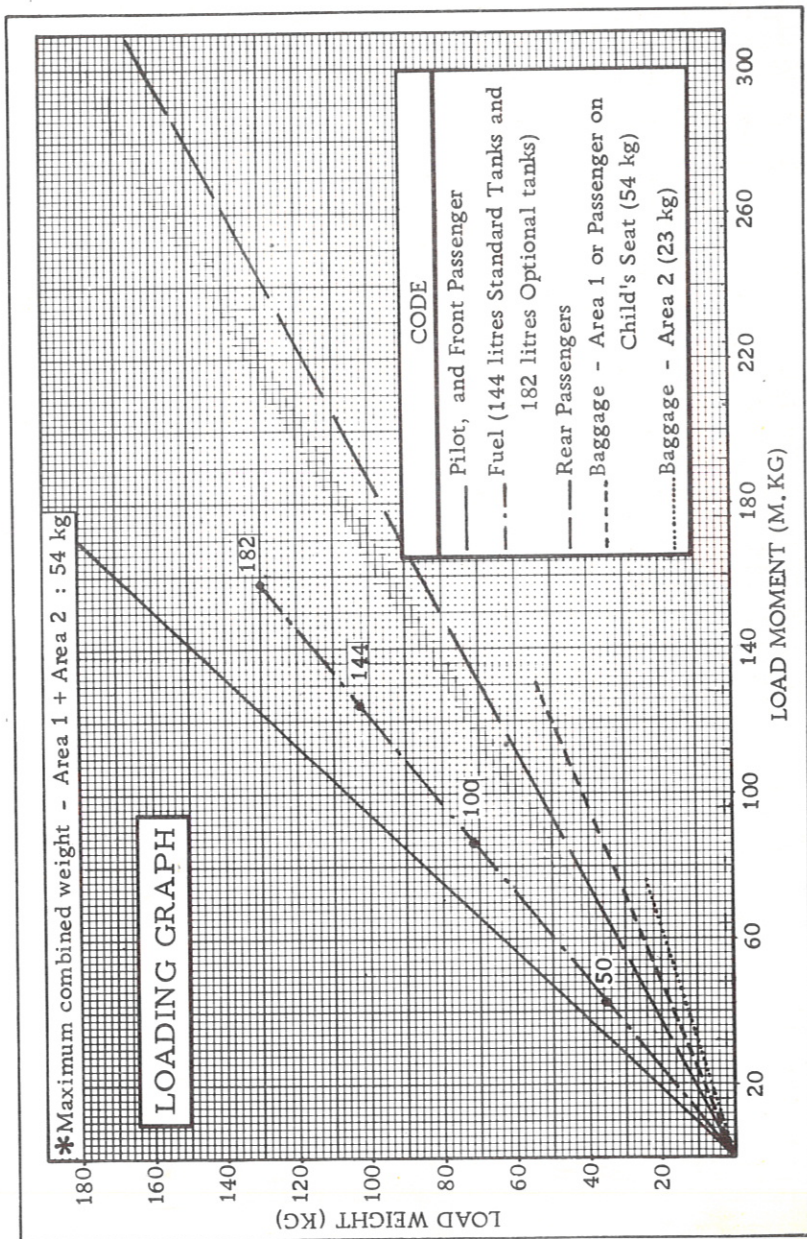

Figure 5

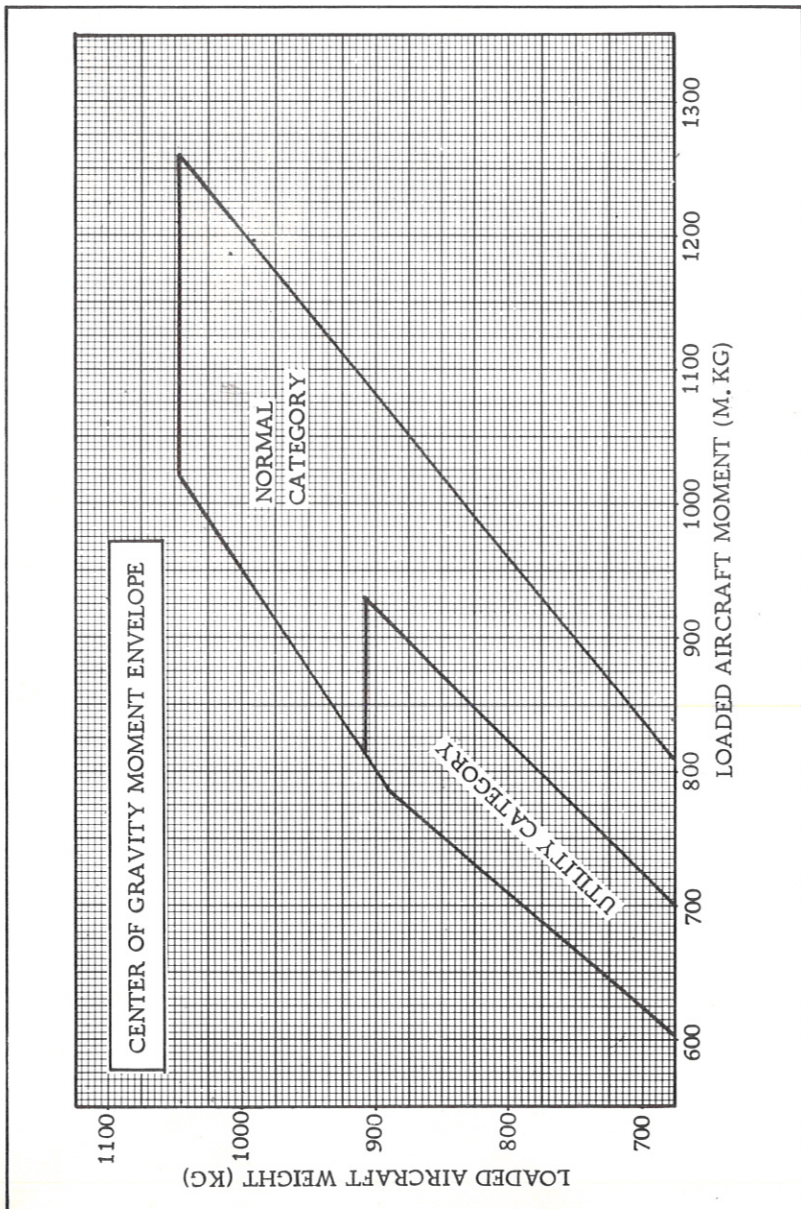

Figure 6

Flight Manual
REIMS/CESSNA F172M

Edition No. 1
September 1972
Revision No. 2
August 1973

EXTERIOR INSPECTION

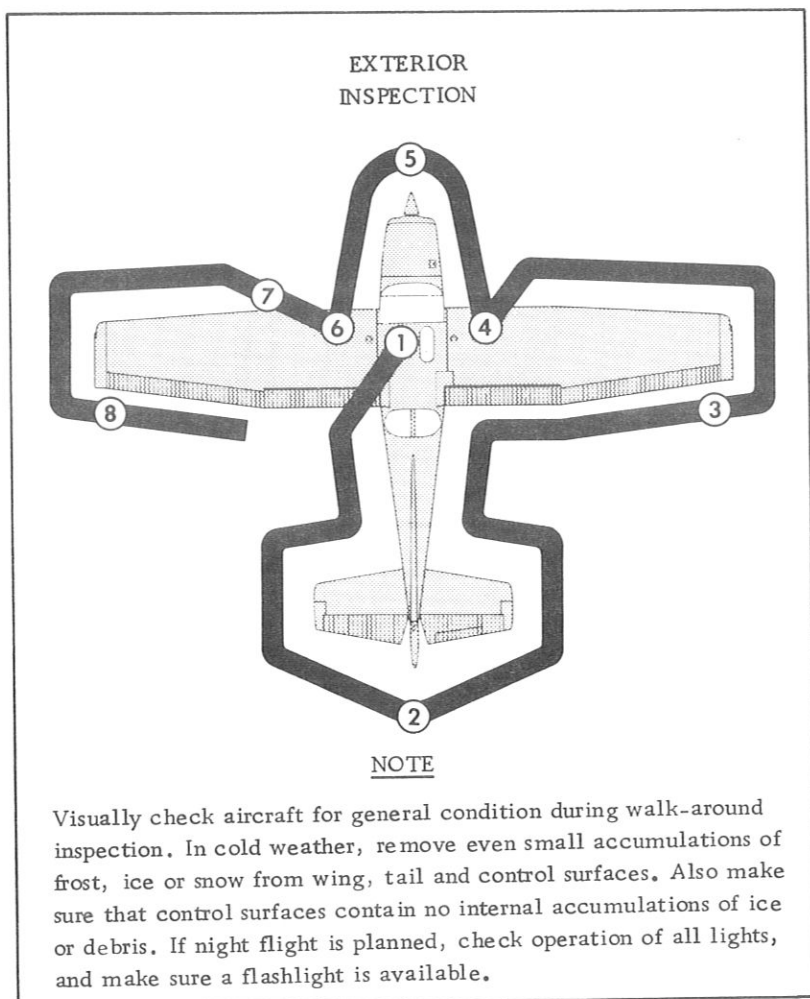

Figure 7

- ① a. Turn on master switch and check fuel quantity indicators, then turn master switch "OFF".
b. Check ignition switch "OFF".
c. Check fuel selector valve handle on "BOTH".
d. Remove control wheel lock.
e. Check baggage door for security. Lock with key if children are to occupy child's seat.

- ② a. Remove rudder gust lock, if installed.
b. Disconnect tail tie-down.
c. Check control surfaces for freedom of movement and security.

- ③ a. Remove aileron gust lock, if installed.

- ④ a. Check main wheel tire for proper inflation.
b. Disconnect wing tie-down.
c. Drain the wing tanks using the sampler cup in the map compartment.
d. Visually check fuel quantity ; then check fuel filler cap secure.

- ⑤ a. Check oil level. Do not operate with less than 5.7 litres (6 qts). Fill to 7.6 litres (8 qts) for extended flights.
b. Before first flight of day and after each refueling, pull out drain plug for about four seconds to clear fuel tanks of possible water and sediment. Check drain plugs closed. If water is observed, the fuel tank sump drain plugs should be removed to check for the presence of water.
c. Check propeller and spinner for condition.
d. Check landing light for condition and cleanliness.
e. Check carburetor air filter for cleanliness.
f. Check nose wheel strut and tire for proper inflation.
g. Disconnect nose tie-down.
h. Inspect flight instrument static source opening on left side of fuselage for stoppage.

- ⑥ - Same as 4 .

- ⑦ a. Remove pitot tube cover, if installed, and check pitot tube opening for stoppage .
b. Check fuel tank vent opening for stoppage .
c. Check stall warning vent opening for stoppage .
d. Disconnect wing tie-down .

- ⑧ - Same as 3 .

OPERATING CHECK LIST

BEFORE ENTERING THE AIRPLANE

- (1) Make an exterior inspection in accordance with figure 7.

BEFORE STARTING THE ENGINE

- (1) Seats, Seat Belts - Adjust and lock.
- (2) Brakes - Test and set.
- (3) Fuel Selector Valve - "BOTH".
- (4) Radios and Electrical Equipment - "OFF".

STARTING THE ENGINE

- (1) Carburetor Heat - Cold.
- (2) Mixture - Rich.
- (3) Primer - As required.
- (4) Throttle - Open 1/2 inch (1 cm).
- (5) Master Switch - "ON".
- (6) Propeller Area - Clear.
- (7) Starter - Engage.
- (8) Oil Pressure - Check.

BEFORE TAKE-OFF

- (1) Parking Brake - Set.
- (2) Flight Controls - Check for free and correct movement.
- (3) Fuel Selector Valve - "BOTH".
- (4) Elevator Trim Control Wheel - "TAKE-OFF" setting.
- (5) Throttle Setting - 1700 RPM.
- (6) Engine Instruments and Ammeter - Check.
- (7) Suction Gage - Check (4.6 to 5.4 inches of mercury).
- (8) Magnetos - Check (RPM drop should not exceed 125 RPM on either magneto or 50 RPM differential between magnetos).

- (9) Carburetor Heat - Check operation.
- (10) Flight Instruments and Radios - Set.
- (11) Optional Autopilot - Off.
- (12) Throttle Friction Lock - Set.

TAKE-OFF

NORMAL TAKE-OFF

- (1) Wing Flaps - Up.
- (2) Carburetor Heat - Cold.
- (3) Throttle - Full "OPEN".
- (4) Elevator Control - Lift nose wheel at 102 km/h - 55 kts - 63 MPH IAS.
- (5) Climb Speed - 130 to 148 km/h - 70 to 80 kts - 81 to 92 MPH IAS.

MAXIMUM PERFORMANCE TAKE-OFF

- (1) Wing Flaps - Up.
- (2) Carburetor Heat - Cold.
- (3) Brakes - Hold.
- (4) Throttle - Full "OPEN".
- (5) Brakes - Release.
- (6) Elevator Control - Slightly tail low.
- (7) Climb Indicated Speed - 109 km/h - 59 kts - 68 MPH until all obstacles are cleared.

CLIMB

NORMAL CLIMB

- (1) Indicated Airspeed - 129 to 145 km/h - 69 to 78 kts - 80 to 90 MPH.
- (2) Power - Full throttle.
- (3) Mixture - Full rich (mixture may be leaned above 3000 ft).

MAXIMUM PERFORMANCE CLIMB

- (1) Indicated Airspeed - 145 km/h - 78 kts - 90 MPH at sea level.
- 126 km/h - 68 kts - 78 MPH at 3048 m - 10,000 ft.

- (2) Power - Full throttle.
- (3) Mixture - Rich.

CRUISING

- (1) Power - 2200 to 2700 RPM.
- (2) Elevator Trim - Adjust.
- (3) Mixture - Lean to maximum RPM.

NOTE

If a loss of RPM is noted, use the carburetor heater (refer to "CARBURETOR ICING" on page 4-21).

LET-DOWN

- (1) Mixture - Rich.
- (2) Power - As desired.
- (3) Carburetor Heat - As required to prevent carburetor icing.

BEFORE LANDING

- (1) Mixture - Rich.
- (2) Fuel Selector Valve - "BOTH".
- (3) Carburetor Heat - Apply full heat before closing throttle.
- (4) Indicated Airspeed - 111 to 130 km/h - 60 to 70 kts - 69 to 81 MPH (flaps up).
- (5) Wing Flaps - As desired below 161 km/h - 87 kts - 100 MPH IAS
- (6) Indicated Airspeed - 102 to 121 km/h - 55 to 65 kts - 63 to 75 MPH (flaps down).

BALKED LANDING

- (1) Power - Full throttle.
- (2) Carburetor Heat - Cold.
- (3) Wing Flaps - Retract to 20°.
- (4) Upon reaching an indicated airspeed of approximately 102 km/h - 55 kts - 63 MPH, retract flaps slowly.

NORMAL LANDING

- (1) Touchdown - Main wheels first.
- (2) Landing Roll - Lower nose wheel gently.
- (3) Braking - Minimum required.

AFTER LANDING

- (1) Wing Flaps - Up.
- (2) Carburetor Heat - Cold.

SECURING THE AIRCRAFT

- (1) Parking Brake - Set.
- (2) Radios and Electrical Equipment - "OFF".
- (3) Mixture - Idle cut-off.
- (4) Ignition and Master Switch - "OFF".
- (5) Control lock - Installed.

OPERATING DETAILS

STARTING ENGINE

Ordinarily the engine starts easily with one or two strokes of primer in warm temperatures to six strokes in cold weather, with the throttle open approximately 1/2 inch (1 cm). In extremely cold temperatures, it may be necessary to continue priming while cranking. Weak intermittent

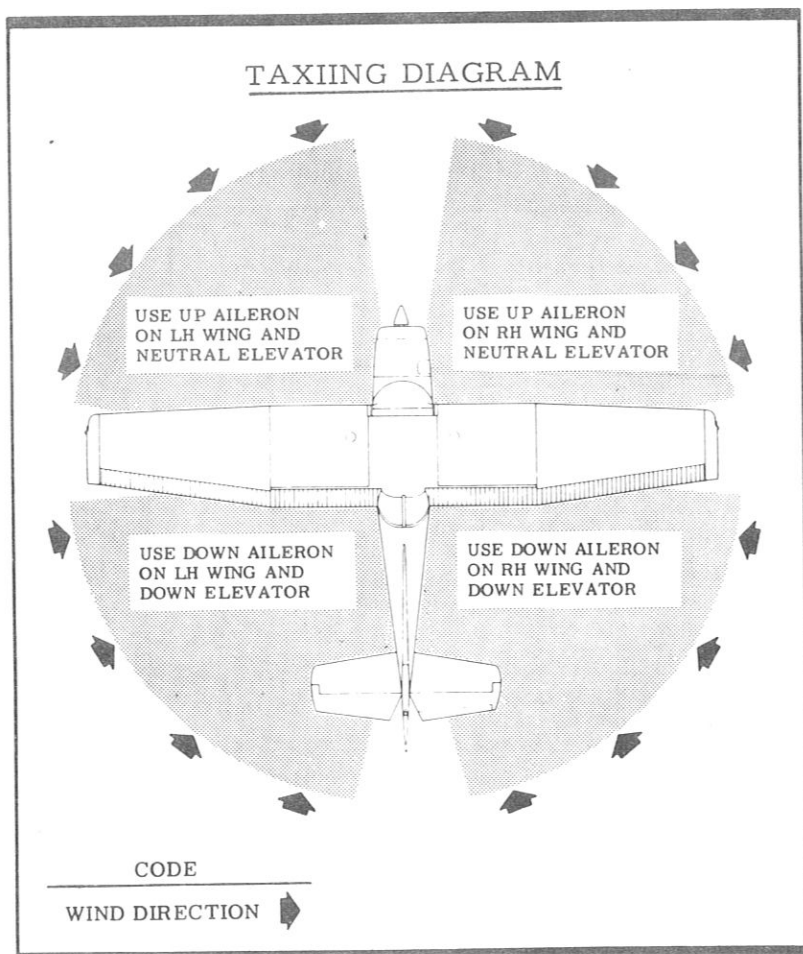

Figure 8

firing followed by puffs of black smoke from the exhaust stack indicate overpriming or flooding. Excess fuel can be cleared from the combustion chambers by the following procedure : Set the mixture control in full lean position, throttle full open, and crank the engine through several revolutions with the starter. Repeat the starting procedure without any additional priming.

If the engine is underprimed it will not fire at all, and additional priming will be necessary.

After starting, if the oil gage does not begin to show pressure within 30 seconds in the summertime and about twice that long in very cold weather, stop engine and investigate. Lack of oil pressure can cause serious engine damage. After starting, avoid the use of carburetor heat unless icing conditions prevail.

TAXIING

When taxiing, it is important that speed and use of brakes be held to a minimum and that all controls be utilized (see taxiing diagram, page 4-13) to maintain directional control and balance. Taxiing over loose gravel or cinders should be done at low engine speed.

The carburetor heat control knob should be pushed full in during all ground operations unless heat is absolutely necessary. When the knob is pulled out to the heat position, air entering the engine is not filtered.

BEFORE TAKE-OFF

WARM-UP

Most of the warm-up will have been conducted during taxi, and additional warm-up before take-off should be restricted to the checks outlined in this Section. Since the engine is closely cowled for efficient inflight cooling, precautions should be taken to avoid overheating on the ground.

MAGNETO CHECK

The magneto check should be made at 1700 RPM as follows :

Move the ignition switch first to "R" position and note RPM, then move switch back to "BOTH" position. Then move switch to "L" position, note RPM and return to "BOTH". RPM drop should not exceed 125 RPM on either magneto or show greater than 50 RPM differential between magnetos. If there is a doubt concerning the operation of the ignition system, RPM checks at higher engine speeds will usually confirm whether a deficiency exists. An absence of RPM drop may be an indication of faulty grounding of one side of the ignition system or should be cause for suspicion that the magneto timing is set in advance of the setting specified.

ALTERNATOR CHECK

Prior to flights where verification of proper alternator and voltage regulator operation is essential (such as night or instrument flights), a positive verification can be made by loading the electrical system momentarily (2 to 5 seconds) with the optional landing light, (if so equipped), or by operating the wing flaps during the engine runup.

The ammeter will remain at zero if the alternator and voltage regulator are operating properly.

TAKE-OFF

POWER CHECKS

It is important to check full-throttle engine operation early in the take-off run. Any signs of rough engine operation or sluggish engine acceleration is good cause for discontinuing the take-off. If this occurs, you are justified in making a thorough full-throttle, static runup before another take-off is attempted. The engine should run smoothly and turn approximately 2300 to 2420 RPM with carburetor heat off and mixture full rich.

NOTE

Carburetor heat should not be used during take-off unless it is absolutely necessary.

Full throttle runups over loose gravel are especially harmful to propeller tips. When take-offs must be made over a gravel surface, it is very important that the throttle be advanced slowly.

Prior to take-off from fields above 915 m (3000 feet) elevation, the mixture should be leaned to give maximum RPM in a full-throttle, static runup.

The throttle being in the full open position, tighten the friction lock to prevent the throttle lever from moving back. For the other flight configurations, adjust the friction lock as required to maintain a constant throttle position.

FLAP SETTINGS

Normal take-offs are performed with flaps up. The use of 10° flaps will shorten the ground run approximately 10 %, but this advantage is lost in the climb to a 50-foot (15 m) obstacle. Therefore, the use of 10° flaps is reserved for minimum ground runs or for take-off from soft or rough fields. If 10° of flaps are used in ground runs, it is preferable to leave them extended rather than retract them in the climb to the obstacle at 102 km/h - 55 kts - 63 MPH IAS. As soon as the obstacle is cleared, the flaps may be retracted as the aircraft accelerates to the flaps-up maximum rate-of-climb indicated airspeed of 130 to 148 km/h - 70 to 80 kts - 81 to 92 MPH.

During a high altitude take-off in hot weather where climb would be marginal with 10° flaps, it is recommended that the flaps not be used for take-off. Flap settings greater than 10° are not recommended at any time for take-off.

CROSSWIND TAKE-OFFS.

Take-offs into strong crosswinds normally are performed with the minimum flap setting necessary for the field length to minimize the drift angle immediately after take-off. The aircraft is accelerated to a speed slightly higher than normal, then pulled off abruptly to prevent possible settling back to the runway while drifting. When clear of the ground, make a coordinated turn into the wind to correct for drift.

CLIMB

For detailed data, see Maximum Rate-Of-Climb Data chart.

CLIMB SPEEDS

Normal climbs are conducted at 129 to 145 km/h - 69 to 78 kts - 80 to 90 MPH IAS with flaps up and full throttle, for best engine cooling. The mixture should be full rich below 915 m - 3000 ft and may be leaned above 915 m - 3000 ft for smoother engine operation. The best rate-of-climb indicated airspeed range from 145 km/h - 78 kts - 90 MPH at sea level to 126 km/h - 68 kts - 78 MPH at 3048 m - 10,000 ft. If an obstruction dictates the use of a steep climb angle, climb at an obstacle clearance indicated airspeed of 121 km/h - 65 kts - 75 MPH with flaps retracted.

NOTE

Steep climbs at low speeds should be of short duration to allow improved engine cooling.

CRUISE

Normal cruising is done between 55 % and 75 % power. The power settings required to obtain these powers at various altitudes and outside air temperatures can be determined by using your Cessna Power Computer or the PERFORMANCE DATA, Section 5.

The higher the cruise altitude, the higher the true airspeed for the same power.

This is illustrated in the following figure which shows performance at 75 % power at various altitudes.

MAXIMUM CRUISE SPEED PERFORMANCE
75 % POWER

ALTITUDE	RPM	TRUE AIRSPEED		
		km/h	kts	MPH
Sea Level	2500	208	112	129
1220 m - 4000 ft	2600	215	116	134
2440 m - 8000 ft	2700	222	120	138

The use of full carburetor heat is recommended during flight in heavy rain to avoid the possibility of engine stoppage due to excessive water ingestion or to carburetor icing. The mixture setting should be readjusted for smoothest operation.

NOTES

- (1) In extremely heavy rain, the use of partial carburetor heat (control approximately 2/3 out), and part throttle (closed at least 2.5 cm - 1 in.), may be necessary to retain adequate power. Power changes should be made cautiously followed by prompt adjustment of the mixture for smoothest operation.

- (2) At temperatures lower than 0°C (32°F), partial carburetor heat should be avoided since the temperature rise obtained (0° to 21°C - 32° to 70°F) may cause carburetor icing in certain atmospheric conditions.

STALLS

The stall characteristics are conventional for the flaps up and flaps down condition. Slight buffeting may occur just before the stall with flaps down.

Figure 4 of Section 5 shows the stall indicated airspeeds with respect to the flaps position and angle of bank of the aircraft for maximum weight.

With aircraft weights lower than the full gross weight, stall speeds are reduced. The stall warning horn produces a steady signal 9 to 18 km/h - 5 to 10 kts - 6 to 12 MPH before the actual stall is reached and remains on until the normal flight attitude is resumed.

LANDINGS

Normal landings are made with power-off and with flaps as required. Steep slips with flap settings greater than 20° are prohibited in the landing approach. Final approaches are performed at indicated airspeeds of 113 to 129 km/h - 61 to 69 kts - 70 to 80 MPH with flaps up, and 105 to 121 km/h - 56 to 65 kts - 65 to 75 MPH with flaps down, depending on the air turbulence.

NOTE

Carburetor heat should be applied prior to any significant reduction or closing of the throttle.

SHORT FIELD LANDING

For short field landings, in calm air, make a power-off approach at approximately 111 km/h - 60 kts - 69 MPH indicated airspeed with 40° of flaps. Touchdown should be made on the main wheels first. Immediately after touchdown, lower the nose gear to the ground and apply heavy braking as required. For maximum brake effectiveness after all three wheels are on the ground, retract the flaps, hold full nose up elevator and apply maximum possible brake pressure without sliding the tires.

Use of a slightly higher approach speed and partial power for better control to touchdown is recommended when turbulence or strong headwinds are present.

CROSSWIND LANDING

When landing in a strong crosswind, use the minimum flap setting required for the field length. Use a wing low, crab, or a combination method of drift correction and land in a nearly level attitude. Maintain directional control by using the nose wheel steering system and the brakes.

BALKED LANDING

In a balked landing (go-around) climb, the wing flap setting should be reduced to 20° immediately after full power is applied. Upon reaching a safe airspeed, the flaps should be slowly retracted to the full up position. If obstacles must be cleared during the go-around climb, leave the wing flaps in the 10° to 20° range and maintain a climb indicated airspeed of 102 to 111 km/h - 55 to 60 kts - 63 to 69 MPH until the obstacles are cleared. Above 915 m - 3000 feet, lean the mixture to obtain maximum RPH. After clearing any obstacles, the flaps may be retracted as the aircraft accelerates to the flaps-up best rate of climb indicated airspeed of 130 to 148 km/h - 70 to 80 kts - 81 to 92 MPH.

COLD WEATHER OPERATION

Prior to starting on cold mornings, it is advisable to pull the propeller through several times by hand. In extremely cold (- 20°C and lower) weather, the use of an external preheater is recommended.

Cold weather starting procedures are as follows :

With Preheat :

- (1) With ignition switch "OFF" and throttle closed, prime the engine four to eight strokes as the propeller is being turned over by hand.

NOTE

Use heavy strokes of primer for best atomization of fuel. After priming, check that the primer is in the locked position.

- (2) Propeller Area - Clear.
- (3) Master Switch - "ON".
- (4) Mixture - Rich.
- (5) Throttle - Open 1/8 inch (1/2 cm).
- (6) Ignition Switch - "START".
- (7) Release ignition switch to "BOTH" when engine starts.
- (8) Oil Pressure - Check.

Without Preheat :

- (1) Prime the engine six to ten strokes while the propeller is being turned by hand with throttle closed. Leave primer charged and ready for stroke.
- (2) Propeller Area - Clear.
- (3) Master Switch - "ON".
- (4) Mixture - Rich.
- (5) Ignition Switch - "START".
- (6) Pump throttle rapidly to full open twice. Return to 1/8 inch (1/2 cm) open position.
- (7) Release ignition switch to "BOTH" when engine starts.
- (8) Continue to prime engine until it is running smoothly.
- (9) Oil Pressure - Check.
- (10) Pull carburetor heat knob full on after engine has started. Leave on until engine is running smoothly.
- (11) Lock primer.

NOTE

If the engine does not start, it is probable that the spark plugs have been frosted over. Preheat must be used before another start is attempted.

IMPORTANT

Pumping the throttle may cause raw fuel to accumulate in the intake air duct, creating a fire hazard in the event of a backfire. If this occurs, maintain a cranking action to suck flames into the engine. An outside attendant with a fire extinguisher is advised for cold starts without preheat.

BEFORE TAKE-OFF

After a suitable warm-up period (5 minutes at 1000 RPM), accelerate the engine several times to higher engine RPM. If the engine accelerates smoothly and the oil pressure remains normal and steady, the airplane is ready for take-off.

ROUGH ENGINE OPERATION OR LOSS OF POWER

CARBURETOR ICING

A gradual loss of RPM and eventual engine roughness may result from the formation of carburetor ice. To clear the ice, apply full throttle and pull the carburetor heat knob full out until the engine runs smoothly; then remove carburetor heat and readjust the throttle.

If conditions require the continued use of carburetor heat in cruise flight, use the minimum amount of heat necessary to prevent ice from forming and lean the mixture slightly for smoothest engine operation.

SPARK PLUG FOULING

A slight engine roughness in flight may be caused by one or more spark plugs becoming fouled by carbon or lead deposits. This may be verified by turning the ignition switch momentarily from "BOTH" to either "L" or "R" position. An obvious power loss in single ignition operation is evidence of spark plug or magneto trouble. Assuming that spark plugs are the more likely cause, lean the mixture to the normal lean setting for cruising flight. If the problem does not clear up in several minutes, determine if a richer mixture setting will produce smoother operation. If not, proceed to the nearest airport for repairs using the "BOTH" position of the ignition switch unless extreme roughness dictates the use of a single ignition position.

MAGNETO MALFUNCTION

A sudden engine roughness or misfiring is usually evidence of magneto problems. Switching from "BOTH" to either "L" or "R" ignition switch position will identify which magneto is malfunctioning. Select different power settings and enrichen the mixture to determine if continued operation on "BOTH" magnetos is practicable. If not, switch to the good magneto and proceed to the nearest airport for repairs.

LOW OIL PRESSURE

If low oil pressure is accompanied by normal oil temperature, there is a possibility the oil pressure gage or relief valve is malfunctioning. A leak in the line to the gage is not necessarily cause for an immediate precautionary landing because an orifice in this line will prevent a sudden loss of oil from the engine sump. However, a landing at the nearest airport would be advisable to inspect the source of trouble.

If a total loss of oil pressure is accompanied by a rise in oil temperature, there is good reason to suspect an engine failure is imminent. Reduce engine power immediately and select a suitable forced landing field. Leave the engine running at low power during the approach, using only the minimum power required to reach the desired touchdown spot.

SPECIFIC OPERATION

SPIN (Utility Category)

The spin is a prolonged stall that results in a rapid nose-down rotation, the airplane following a helical path. The rotation is the result of a sustained yaw that causes the slower moving wing to almost completely stall while the outer wing retains a portion of its lift. In essence, the rotation is a result of the relatively unstalled outer wing "chasing" the stalled inner wing.

Spins should be practiced at altitudes of 3000 feet (915 m) or more above the surface.

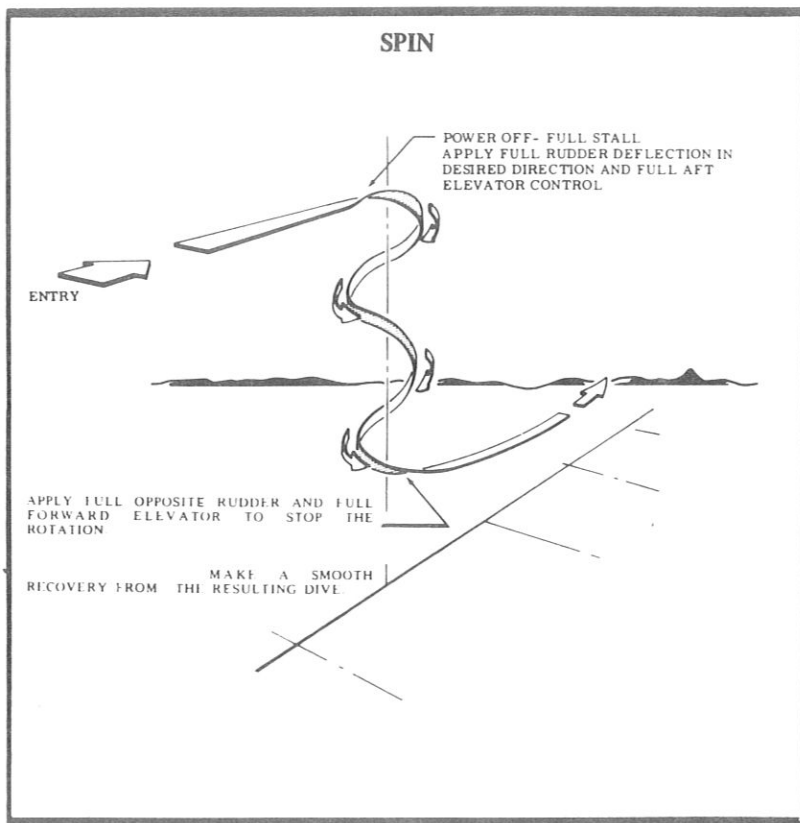

Figure 10

The normal entry is made from a power-off stall. As the stall is approached, the elevator control should be smoothly pulled to the full aft position. Just prior to reaching the stall "break", rudder control in the desired direction of the spin rotation should be applied so that full rudder deflection is reached almost simultaneously with reaching full aft elevator. Care should be taken to avoid using aileron control since its application can increase the rotation and cause erratic rotation.

Both elevator and rudder controls should be held full with the spin until the spin recovery is initiated. An inadvertent relaxation of either of these controls could result in the development of a nose-down spiral.

The normal spin recovery technique is as follows :

- (1) Apply full opposite rudder against the direction of rotation.
- (2) After one-fourth turn, move the elevator control forward of neutral in a brisk motion.
- (3) Neutralize aileron control.
- (4) As the rotation stops, neutralize rudder, and make a smooth recovery from the resulting dive.

Partial power may be used to provide more rapid and precise entries. However, once the spin rotation is established, the throttle must be retarded to the idle position.

PERFORMANCE

NOTIFICATION

The tables appearing on the following pages result from actual tests with an airplane in good flying condition. They will be useful in flight planning ; nevertheless, it will be advisable to plan on an ample safety margin concerning the fuel reserve at arrival, since the data given does not take into account the effects of wind, navigational errors, pilot technique, run-up, climb, etc. All these factors should be considered when estimating the reserve required by regulations. Don't forget that maximum range increases by using a lower power setting. To solve these problems, consult the Cruise Performance table.

In the Table 2, range and endurance are given for lean mixture from 2500 feet to 12,500 feet. All figures are based on zero wind, 144 litres of fuel for cruise, 1043 kg gross weight and standard atmospheric conditions.

PERFORMANCEGROSS WEIGHT

1043 kg

SPEED :

Top Speed at Sea Level

232 km/h - 125 kts - 144 MPH

Cruise, 75 % Power at 2440 m - 8000 ft

222 km/h - 120 kts - 138 MPH

RANGE :

Cruise, 75 % Power at 2440 m - 8000 ft

1046 km - 565 NM

38 US Gal. (144 l), No Reserve

4.7 hrs

Cruise, 75 % Power at 2440 m - 8000 ft

222 km/h - 120 kts - 138 MPH

48 US Gal. (182 l), No Reserve

1312 km - 708 NM

5.9 hrs

Optimum Range at 3048 m - 10,000 ft

222 km/h - 120 kts - 138 MPH

38 US Gal. (144 l), No Reserve

1127 km - 608 NM

6.0 hrs

Optimum Range at 3048 m - 10,000 ft

188 km/h - 102 kts - 117 MPH

48 US Gal. (182 l), No Reserve

1408 km - 760 NM

7.5 hrs

RATE OF CLIMB AT SEA LEVEL

188 km/h - 102 kts - 117 MPH

3.3 m/s - 645 fpm

SERVICE CEILING

4000 m - 13,100 ft

SPECIFICATIONS

<u>TAKE-OFF :</u>	
Ground Run	263 m
Total Distance Over 50-Ft Obstacle	465 m
<u>LANDING :</u>	
Ground Roll	158 m
Total Distance Over 50-Ft Obstacle	381 m
<u>EMPTY WEIGHT (Approximate)</u>	618 kg
<u>BAGGAGE</u>	54 kg
<u>WING LOADING</u>	64 kg/m ²
<u>POWER LOADING</u>	9.32 kg/kW
<u>TOTAL FUEL CAPACITY</u>	159 litres - 42 US Gal.
<u>OIL TANK CAPACITY</u>	7.5 litres - 8 qts
<u>PROPELLER : Fixed Pitch (Diameter)</u>	1.91 m
<u>ENGINE : Lycoming engine 150 rated HP at 2700 RPM</u>	Type O-320 E2D - 112 kW

Table 1

CRUISE PERFORMANCE

ALTITUDE m ft	RPM	% BHP	FUEL CONSUMPTION (PER HOUR) Litres	TAS		144 LITRES (NO RESERVE)		182 LITRES (NO RESERVE)				
				km/h	kts	MPH	Endurance Hours	Range km	NM	Endurance Hours	Range km	NM
762 2500	2700	87	36.4	224	121	139	3.9	880	475	5.0	1110	600
	2600	78	32.6	214	116	133	4.4	955	515	5.6	1205	650
	2500	70	29.2	205	111	128	4.9	1010	545	6.2	1280	690
	2400	63	26.9	196	106	122	5.3	1055	570	6.7	1353	720
	2300	57	25.0	187	101	116	5.7	1065	575	7.2	1350	730
1524 5000	2200	51	23.5	174	94	108	6.1	1075	580	7.7	1350	730
	2700	81	33.7	222	120	138	4.3	945	510	5.4	1195	645
	2600	73	30.7	215	116	133	4.7	1010	545	6.0	1280	690
	2500	66	28.0	205	111	128	5.1	1055	570	6.5	1335	720
	2400	60	25.8	194	105	121	5.6	1085	585	7.0	1370	740
2286 7500	2300	54	24.3	183	99	114	5.9	1095	590	7.5	1370	740
	2200	48	22.7	172	93	107	6.3	1085	585	8.0	1370	740
	2700	76	32.0	222	120	138	4.5	1010	545	5.7	1280	690
	2600	69	28.8	213	115	132	5.0	1065	575	6.3	1345	725

	2500	63	26.9	204	110	127	5.4	1095	590	6.8	1380	745
	2400	57	25.0	193	104	120	5.8	1100	595	7.3	1400	755
	2300	51	23.5	179	97	112	6.1	1100	595	7.8	1400	755
3048	2700	72	29.9	222	120	138	4.8	1075	580	6.1	1380	730
	2600	66	27.6	211	114	131	5.2	1100	595	6.6	1390	750
	2500	59	25.6	200	108	124	5.6	1120	605	7.1	1415	765
	2400	54	24.2	188	102	117	6.0	1120	605	7.5	1415	765
	2300	48	22.7	177	96	110	6.3	1120	605	8.0	1415	765
3800	2650	65	27.3	213	115	132	5.3	1120	605	6.6	1415	765
	2500	56	24.6	196	106	122	5.8	1140	615	7.3	1435	775
	2400	51	23.5	185	100	115	6.2	1150	620	7.8	1445	780
<p>NOTES :</p> <ol style="list-style-type: none"> 1. Maximum cruise is normally limited to 75 % power. 2. In the above calculations of endurance in hours and range, no allowances were made for take-off or reserve. 3. These performance data are computed for an aircraft fitted with wheel fairings. Subtract 1 to 2.5 kts from the highest cruise speeds for the "Standard" aircraft version. 												

Table 2

AIRPEED CORRECTION TABLE

FLAPS UP												
IAS	km/h	74	93	111	130	148	167	185	204	222	241	259
CAS	km/h	91	102	115	130	148	165	183	200	219	237	256
IAS	kts	40	50	60	70	80	90	100	110	120	130	140
CAS	kts	49	55	62	70	80	89	99	108	118	128	138
IAS	MPH	46	58	69	81	92	104	115	125	138	150	161
CAS	MPH	56	63	71	81	92	102	114	124	136	147	159
FLAPS DOWN												
IAS	km/h	74	93	111	130	148	167					
CAS	km/h	87	100	115	132	150	169					
IAS	kts	40	50	60	70	80	90					
CAS	kts	47	54	62	71	81	91					
IAS	MPH	46	58	69	81	92	104					
CAS	MPH	54	62	71	82	93	105					







POWER OFF	STALL INDICATED AIRSPEEDS	ANGLE OF BANK				km/h - kts - MPH
		0°	20°	40°	60°	
MAXIMUM GROSS WEIGHT 1043 kg CONDITIONS						
 FLAPS UP	87 km/h 47 kts 54 MPH	89 km/h 48 kts 55 MPH	100 km/h 54 kts 62 MPH	122 km/h 66 kts 76 MPH		
 FLAPS 10°	82 km/h 44 kts 51 MPH	83 km/h 45 kts 52 MPH	93 km/h 50 kts 58 MPH	115 km/h 62 kts 71 MPH		
 FLAPS 40°	78 km/h 42 kts 48 MPH	80 km/h 43 kts 49 MPH	89 km/h 48 kts 55 MPH	109 km/h 59 kts 68 MPH		

Table 4

		TAKE-OFF DISTANCE				FLAPS RETRACTED HARD SURFACE RUNWAY					
GROSS WEIGHT	IAS 15 m	HEAD WIND	AT SEA LEVEL AND + 15°C		AT 762 M - 2500 FT AND + 10°C		AT 1524 M - 5000 FT AND + 5°C		AT 2286 M - 7500 FT AND 0°C		
			Ground Run	Total to Clear 15 m Obs	Ground Run	Total to Clear 15 m Obs	Ground Run	Total to Clear 15 m Obs	Ground Run	Total to Clear 15 m Obs	
		WIND									
		km/h	fts								
750	92 km/h	0		125	224	149	264	178	314	218	390
	50 kts	18	10	84	163	101	195	122	233	152	294
	57 MPH	37	20	49	110	61	133	76	163	98	209
900	101 km/h	0		189	328	226	396	271	485	334	640
	55 kts	18	10	130	245	158	300	192	372	241	500
	63 MPH	37	20	82	172	102	215	126	271	163	372
1043	109 km/h	0		263	465	317	582	383	756	477	1175
	59 kts	18	10	187	357	229	453	280	596	354	948
	68 MPH	37	20	123	259	154	335	192	451	247	739

NOTE : 1) Increase the distance by 10 % for each 15°C increase in temperature above standard for the particular altitude.

2) For operation on a dry, grass runway, increase distances (both "ground run" and "total to clear 15 m obstacle") by 7 % of the "total to clear 15 m obstacle" figure.

Table 5

		FLAPS LOWERED 40° POWER OFF - ZERO WIND HARD SURFACE RUNWAY							
		LANDING DISTANCE		AT 762 M - 2500 FT AND + 10°C		AT 1524 M - 5000 FT AND + 5°C		AT 2286 M - 7500 FT AND 0°C	
GROSS WEIGHT kg	APPROACH SPEED	AT SEA LEVEL AND + 15°C		Total to Clear 15 m Obs		Total to Clear 15 m Obs		Total to Clear 15 m Obs	
		Ground Roll m	m	Ground Roll m	m	Ground Roll m	m	Ground Roll m	m
	111 km/h								
1043	60 kts	158	381	170	400	184	422	200	445
	69 MPH								

NOTE : 1) Decrease distances shown by 10 % for each 5 kts headwind.
Increase the distance by 10 % for each 15°C temperature increase above standard.

2) For operation on a dry, grass runway, increase distances (both "ground roll" and "total to clear 15 m obstacle") by 20 % of the "total to clear 15 m obstacle" figure.

Table 6

MAXIMUM RATE OF CLIMB DATA												
FLAPS RETRACTED FULL THROTTLE												
GROSS WEIGHT	AT SEA LEVEL AND + 15°C			AT 1524 M - 5000 FT AND + 5°C			AT 3048 M - 10,000 FT AND - 5°C			AT 4572 M - 15,000 FT AND - 15°C		
	IAS	Rate of Climb	Fuel Used	IAS	Rate of Climb	Fuel Used	IAS	Rate of Climb	Fuel Used	IAS	Rate of Climb	Fuel Used
750 kg	135 km/h 73 kts 84 MPH	1085 ft/min	3.8 litres	128 km/h 69 kts 79 MPH	825 ft/min	7.2 litres	117 km/h 63 kts 73 MPH	570 ft/min	10.6 litres	106 km/h 57 kts 66 MPH	315 ft/min	15.5 litres
900 kg	141 km/h 76 kts 88 MPH	840 ft/min	3.8 litres	132 km/h 71 kts 82 MPH	610 ft/min	8.3 litres	120 km/h 65 kts 75 MPH	380 ft/min	13.6 litres	110 km/h 59 kts 68 MPH	155 ft/min	23.5 litres
1043 kg	145 km/h 78 kts 90 MPH	645 ft/min	3.8 litres	135 km/h 73 kts 84 MPH	435 ft/min	9.9 litres	126 km/h 68 kts 78 MPH	230 ft/min	18.2 litres	115 km/h 62 kts 71 MPH	20 ft/min	43.5 litres

NOTE : Flaps retracted, full throttle, mixture leaned above 915 m - 3000 feet.
Fuel used includes warm-up and take-off allowances.
For hot weather, decrease rate of climb 20 ft/min for each 5°C above standard day temperature for particular altitude.

Table 7

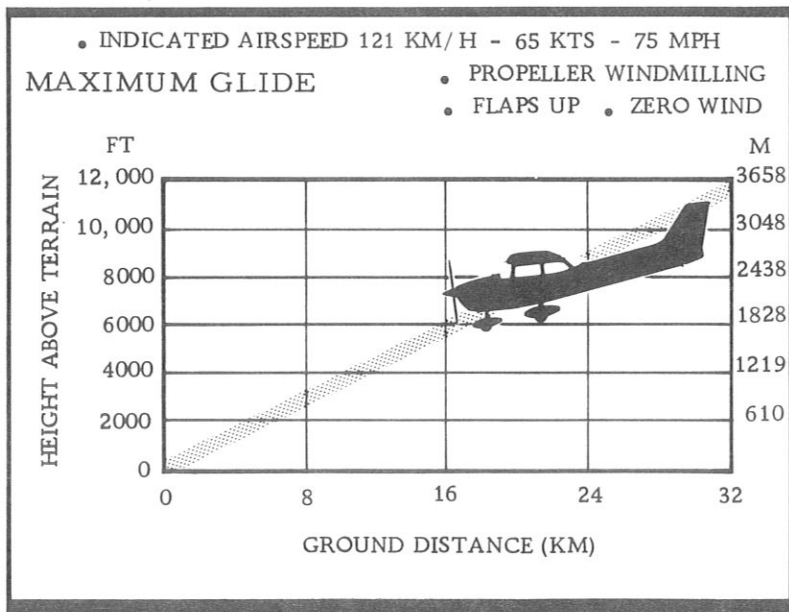

Figure 9

CROSSWIND LIMITATIONS

Take-off direct crosswind limitation 37 km/h - 20 kts.

Landing direct crosswind limitation 28 km/h - 15 kts.

SERVICING

For quick and ready reference, quantities, materials, and specifications for frequently used service items (such as fuel, oil, etc.) are shown in the following pages.

In addition to the PREFLIGHT INSPECTION covered in Section 4, COMPLETE servicing, inspection, and test requirements for your aircraft are detailed in the aircraft Service Manual. The Service Manual outlines all items which require attention at 50, 100, and 200 hour intervals plus those items which require servicing, inspection, and/or testing at special intervals.

Since Dealers conduct all service, inspection, and test procedures in accordance with applicable Service Manuals, it is recommended that you contact your Dealer concerning these requirements and begin scheduling your aircraft for service at the recommended intervals.

The manufacturer Progressive Care ensures that these requirements are accomplished at the required intervals to comply with the 100-HOUR or ANNUAL inspection as previously covered. Depending on various flight operations, your local Government Aviation Agency may require additional service, inspections, or tests.

For these regulatory requirements, owners should check with local aviation officials where the aircraft is being operated.

ENGINE OIL

Aviation grade engine oil SAE 50 above 15°C (59°F), SAE 40 at temperatures from -1° to +30°C (+30° to +86°F), SAE 10W30 or SAE 30 at temperatures from -20° to + 20°C (-4° to +68°F) and SAE 20 at temperatures below -10°C (+14°F). (Multi-viscosity oil with a range of SAE 10W30 is recommended for improved starting in cold weather.)

Detergent or dispersant oil conforming to specification MIL-L-22851 must be used

NOTE

The aircraft was delivered from the factory with a corrosion preventive aircraft engine oil. If oil must be added during the first 25 hours, use only aviation grade straight mineral oil (non-detergent) conforming to Specification No. MIL-L-6082.

OIL SUMP CAPACITY : 8 QTS (7.6 LITRES)

Do not operate on less than 6 qts (5.7 litres). To minimize loss of oil through breather, fill to 7 qts (6.6 litres) for normal flights of less than 3 hours. For extended flight, fill to 8 qts (7.6 litres). (Quantities shown above are oil dipstick level only). If optional oil filter is installed, one additional quart (0.9 litre) is required when oil and the filter element are changed.

ENGINE OIL SUMP AND OIL FILTER CHANGE

After first 25 hours of operation, drain engine oil sump and oil cooler and clean both the oil suction strainer and oil pressure screen. If an optional oil filter is installed, change filter element at this time. Refill sump with straight mineral oil (non-detergent) and use until a total of 50 hours have accumulated, then change to detergent oil.

Drain the engine oil sump and oil cooler and clean both the oil suction strainer and oil pressure screen at 50-hour intervals.

On the aircraft which have an optional oil filter, the oil change interval may be extended to 100-hour interval providing the oil filter element is changed at 50-hour intervals.

In all cases, change the oil even though less than 50 hours have accumulated within a six-month period. Reduce periods for prolonged operation in dusty areas, cold climates, or when short flights and long idle periods result in sludging conditions.

FUEL

FUEL GRADE : Aviation grade 80/87 minimum or 100L .

NOTE

100/130 Aviation Grade Fuel with maximum lead content of 4.6 cc per gallon is also approved for use (Refer to AVCO LYCOMING Service Bulletin N° 1070F).

FUEL TANK CAPACITY (EACH STANDARD TANK) : 79.5 litres (21 US Gal.)

FUEL TANK CAPACITY (EACH LONG RANGE TANK) : 98.5 litres (26 US Gal.)

NOTE

To ensure maximum fuel capacity when refueling, place fuel selector valve in either "LEFT" or "RIGHT" position to prevent cross-feeding.

LANDING GEAR

NOSE WHEEL TIRE AND PRESSURE :

5.00 x 5 - 4 PR 2.14 bar - 31 psi

6.00 x 6 - 4 PR 1.79 bar - 26 psi

MAIN WHEEL TIRE AND PRESSURE :

6.00 x 6 - 4 PR 2.00 bar - 29 psi

NOSE GEAR SHOCK STRUT

Check level, fill as required with MIL-H-5606 hydraulic fluid and inflate with air to 3.1 bars - 45 psi.

NOTE

For complete servicing requirements, refer to the aircraft Service Manual.

MAINTENANCE

GROUND HANDLING

The airplane is most easily and safely maneuvered by hand with a tow-bar attached to the nose wheel.

When using the tow-bar, never exceed the turning angle of 30° either side of center, or damage to the gear will result.

MOORING YOUR AIRPLANE

Proper tie-down is the best precaution against damage to your parked airplane by gusty or strong winds. To tie down your airplane securely, proceed as follows :

- (1) Set parking brake and install control wheel lock.
- (2) Install a control surface lock between each aileron and flap.
- (3) Tie sufficiently strong ropes to wing and tail tie-down fittings, and secure each rope to ramp tie-down.
- (4) Install a control surface lock over the fin and rudder.
- (5) Install a pitot tube cover.

WINDSHIELD - WINDOWS

The windshield and windows should be kept clean at all times. Wash them carefully with plenty of soap and water, using palm of hand. Chamois or sponge may be used, but only to carry water to the surface. Rinse thoroughly, then dry with a clean, moist chamois.

Rubbing the surface of the plastic with a dry cloth builds up an electrostatic charge which attracts dust particles in the air ; the use of a chamois prevents such a dust attraction.

Remove oil and grease with a cloth moistened with kerosene. Never use gasoline, benzine, alcohol, acetone, carbon tetrachloride, anti-mist

fluid, lacquer thinner, etc. . . These materials will soften the plastic and may cause it to craze.

After removing dirt and grease, the surface may be waxed with a good grade of wax. Apply a thin, even coat of wax and bring it to a high polish by rubbing lightly with a clean, dry, soft flannel cloth. Do not use a power buffer ; the heat generated by the buffing pad may soften the plastic.

PAINTED SURFACES

The painted exterior surfaces of the aircraft require an initial curing period which may be as long as 15 days. During this curing period, some precautions should be taken to avoid damaging the finish. The finish should be cleaned only by washing with clean water and mild soap, followed by a rinse water and drying with chamois. Do not use polish or wax, and avoid flying through rain, hail or sleet during this period. Once the finish has cured completely, wax or polish may be used, particularly on the leading edges, engine nose cap, and propeller spinner to reduce the abrasion encountered in these areas.

PROPELLER CARE

Preflight inspection of propeller blades for nicks, and wiping them occasionally with an oily cloth to clean off grass and bug stains will assure long, trouble-free service. Small nicks on the blades, particularly near the tips and on the leading edges, should be dressed out as soon as possible since these nicks produce stress concentrations, and if ignored, may result in cracks. Never use an alkaline cleaner on the blades ; remove grease and dirt with carbon tetrachloride.

INTERIOR CARE

To remove dust and loose dirt from the upholstery, headliner, and carpet, clean the interior regularly with a vacuum cleaner.

Oily spots may be cleaned with household spot removers, used sparingly. Before using any solvent, test it on an obscure place on the fabric to be cleaned. Never saturate the fabric with a volatile solvent ; it may damage the padding and backing materials.

The "royalite" trim, instrument panel and control knobs need only be wiped off with a damp cloth. Oil and grease on the control wheel and control knobs can be removed with a cloth moistened with kerosene.

Volatile solvents, such as mentioned in paragraphs on care of the windshield, must never be used since they soften and craze the plastic.

OPTIONAL EQUIPMENT LIST

DESCRIPTION	PAGE	APPROVAL
- Winterization Kit	6-1.1	
- Ground Service Plug Receptacle	6-1.1	
- Static Pressure Alternate Source Valve	6-1.2	
- Radio Transmitter Selector Switch	6-1.3	
- Autopilot Omni Switch *	6-1.3	
- Combination Headgear	6-1.3	
- Wing Leveler *	6-1.4	
	and	
	6-1.5	
- Carburetor Air Temperature Gage	6-1.6	
- True Airspeed Indicator	6-1.7	
- Instrument Flying (IFR)	6-1.8	
- Glider Towing Hook	6-1.9 and 6-1.10	
- FERNANDEZ Ski Kit	6-1.11 thru 6-1.15	
- ARC 300 Automatic Pilot	6-1.16 thru 6-1.19	
- Skydiving Kit	6-1.20 thru 6-1.25	
- BADIN CROUZET RG10B Automatic Pilot	6-1.26 thru 6-1.28	



P.O.
Robert

* Deleted

OPTIONAL EQUIPMENT LIST (Cont'd)

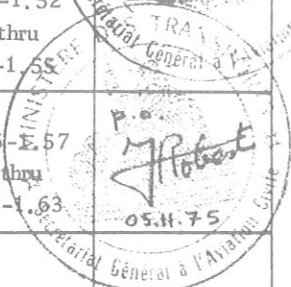
DESCRIPTION	PAGE	APPROVAL
- Floatplane - NAV-O-MATIC 200 A Automatic Pilot	6-1.29 thru 6-1.51 6-1.52 thru 6-1.55	
- NAV-O-MATIC 300 A Automatic Pilot	6-1.57 thru 6-1.63	

13 April 1973
p. o. J. ROBERT
SGAC Approval

WINTERIZATION KIT

For continuous operation in temperatures consistently below 20°F (-7°C), the winterization kit should be installed to improve engine operation.

The kit consists of :

- Two shields to partially cover the cowl nose cap openings.
- One shield to partially cover the oil cooler air inlet at the RH rear side of the engine.
- An insulation for the engine crankcase breather line.

NOTE

Once installed, the crankcase breather insulation is approved for permanent use in both cold and hot weather.

GROUND SERVICE PLUG RECEPTACLE

A ground service plug receptacle may be installed to permit the use of an external power source for cold weather starting and during lengthy maintenance work on the airplane electrical system (with the exception of electronic equipment).

Electrical power for the airplane electrical circuits is provided through a split bus bar having all electronic circuits on one side of the bus and other electrical circuits on the other side of the bus. When an external power source is connected, a contactor automatically opens the circuit to the electronic portion of the split bus bar as a protection against damage to the transistors in the electronic equipment by transient voltages from the power source. Therefore, the external power source can not be used as a source of power when checking electronic components. Just before connecting an external power source, the master switch should be turned "ON". The ground service plug receptacle circuit incorporates a polarity reversal protection. Power from the external power source will flow only if the ground service plug is correctly connected to the airplane.

Even when completely discharged, the battery may be charged from the external power source. A special fused circuit in the external power system will close the battery contactor when the master switch is turned "ON".

STATIC PRESSURE ALTERNATE
SOURCE VALVE

A static pressure alternate source valve may be installed in the static system for use when the external static source is malfunctioning. This valve may also be used to drain condensation from the system lines.

If erroneous instrument readings are suspected due to water or ice in the static pressure lines, the static pressure alternate source valve should be opened, thereby supplying static pressure from the cabin. Cabin pressures will vary, however, with open cabin ventilators or windows. The most adverse combinations will result in airspeed and altimeter variations of no more than 11 km/h - 6 kts - 7 MPH and 9 m - 30 feet, respectively.

RADIO SELECTOR SWITCHES

When more than one radio is installed, an audio switching system is necessary. The operation of this switching system is described below.

Transmitter Selector Switch

The transmitter selector switch, labeled "XMTR SEL", has three positions. When three transmitters are installed, it is necessary to switch the microphone to the radio unit the pilot desires to use for transmission. This is accomplished by placing the transmitter selector switch to the radio unit which is to be used.

"Speaker-Phone" Switch

The switch corresponding to the selected receiver is used to apply the output of that receiver either to the speaker through the audio amplifier in the up position or directly to the headphones in the down position.

COMBINATION HEADGEAR

The pilot may transmit by depressing the microphone keying switch located on the left side of the pilot's control wheel. The plug-in jacks are located on the lower left side of the instrument panel.

CARBURETOR AIR TEMPERATURE GAGE

A carburetor air temperature gage may be installed in the aircraft to help detect carburetor icing conditions. The gage is marked with a yellow arc between -15° and $+5^{\circ}\text{C}$. The yellow arc indicates the carburetor temperature range where carburetor icing can occur ; a placard on the gage reads KEEP NEEDLE OUT OF YELLOW ARC DURING POSSIBLE ICING CONDITIONS.

Visible moisture or high humidity can cause carburetor ice formation, especially in idle or low power conditions. Under cruising conditions, the formation of ice is usually slow, providing time to detect the loss of RPM caused by the ice. Carburetor icing during take-off is rare since the full-open throttle condition is less susceptible to ice obstruction.

If the carburetor air temperature gage needle moves into the yellow arc during potential carburetor icing conditions, or there is an unexplained drop in RPM, apply full carburetor heat. Upon regaining the original RPM (with heat off), determine by trial and error the minimum amount of carburetor heat required for ice-free operation.

NOTE

Carburetor heat should not be applied during take-off unless absolutely necessary to obtain smooth engine acceleration (usually in sub-zero temperatures).

TRUE AIRSPEED INDICATOR

A true airspeed indicator is available to replace the standard airspeed indicator in your airplane. The true airspeed indicator has a calibrated rotatable ring which works in conjunction with the airspeed indicator dial in a manner similar to the operation of a flight computer.

TO OBTAIN TRUE AIRSPEED, rotate ring until pressure altitude is aligned with outside air temperature in degrees Fahrenheit. Then read true airspeed on rotatable ring opposite airspeed needle.

NOTE

Pressure altitude should not be confused with indicated altitude. To obtain pressure altitude, set barometric scale on altimeter to "1013 mb" and read pressure altitude on altimeter. Be sure to return altimeter barometric scale to original barometric setting after pressure altitude has been obtained.

INSTRUMENT FLYING (IFR)

For IFR operation, F172M private aircraft must be equipped with the following :

Standard Equipment : S
Optional Equipment : O

DESCRIPTION OF EQUIPMENT	S or O
<u>For Type V Area :</u>	
- One Artificial Horizon	O
- One Gyroscopic Turn Indicator (with supply source separate from that of the artificial horizon)	S
- One Gyroscopic Directional Indicator	O
- One Gyroscopic Instrument Power Monitoring System	O
- A second Sensitive and Adjustable Altimeter	O
- One Pitot Tube and Stall Warning Heater System	O
- One Alternate Static Pressure Source	O
- One Rate of Climb Indicator	O
- One Outside Air Temperature Gage	O
- One Electric Clock with Second Hand	O
- One Flashing Beacon	O
- Position Lights	S
- Landing Lights (on Left Wing)	O
- One Instrument Lighting System	S
- One Pocket with Two Spare Fuses Each Rating	O
- Two Category 2 VHF Transmitter-Receiver	O
- One Category 2 VOR Receiver	O
- One Category 2 ADF System	O
- One Category 2 NAV Receiver with Localizer and ILS Functions	O
- One Category 2 Marker Beacon System	O
<u>For Type H Area :</u>	
- Same Equipment as Type V Area Equipment	
- One Category 2 HF Transmitter-Receiver	O
<u>NOTE</u> : For night flights, the crew should have an electric flashlight available.	

INSTRUMENT PANEL

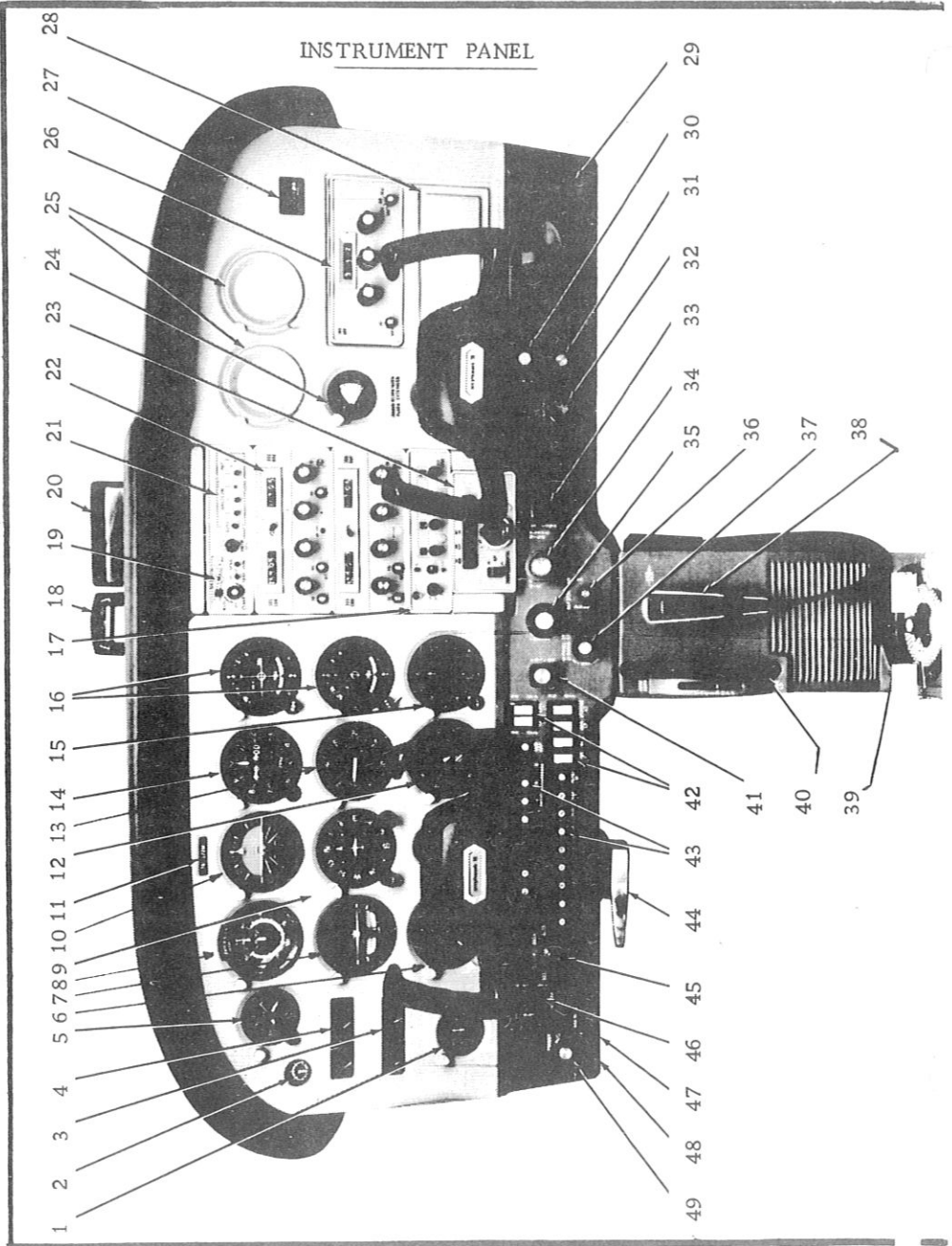

DESCRIPTION

1.	Ammeter	26.	ADF
2.	Suction Gauge	27.	Flight Four Recorder
3.	Oil Temperature and Oil Pressure Gages	28.	Additional Radio Space
4.	Left and Right Fuel Gages	29.	Map Compartment
5.	Clock	30.	Cabin Heat Control Knob
6.	Tachometer	31.	Cabin Air Control Knob
7.	Gyroscopic Turn Indicator	32.	Cigar Lighter
8.	Airspeed Indicator	33.	Wing Flap Switch
9.	Gyroscopic Directional Indicator	34.	Mixture Control Knob
10.	Artificial Horizon	35.	Throttle
11.	Airplane Registration Number	36.	Alternate Static Source Valve
12.	Secondary Altimeter	37.	Instrument and Radio Dial Light Rheostats
13.	Vertical Speed Indicator	38.	Microphone
14.	Encoding Altimeter	39.	Fuel Selector Valve Handle
15.	ADF Bearing Indicator	40.	Elevator Trim Control Wheel
16.	Omni Course Indicators	41.	Carburetor Trim Control Knob
17.	Transponder	42.	Electrical Switches
18.	Magnetic Compass	43.	Circuit Breakers
19.	Marker Beacon Indicator Lights and Switches	44.	Parking Brake Handle
20.	Rear View Mirror	45.	Ignition Switch
21.	Radio Selector Switches	46.	Master Switch
22.	Over Voltage Warning Light	47.	Auxiliary Mike Jack
23.	Autopilot Control Unit	48.	Phone Jack
24.	Wing Flap Position Indicator	49.	Primer
25.	Additional Instrument Space		

GLIDER TOWING HOOK CES-RA-F. 172. 02

BREAKDOWN OF OPTION

- A structural reinforcement factory-installed on aircraft.
- A welded tube frame fitted with an AERAZUR AIR type 12A hook.
- A release control handle on cabin LH side near pilot.
- Two rear view mirrors on wing struts.
- An operating instruction placard near the release control.

OPERATION REQUIREMENTS

- Maximum weight of towed glider : 500 kg
- Maximum weight of towing aircraft : 820 kg
(i. e. pilot + 80 litres fuel)

GLIDER TOWING PROCEDURE

In addition to normal operating procedures :

- Functionally test aircraft and glider hooks.
- Wing flaps : 15°.
- Full throttle power.
- Lift off nose wheel at IAS = 96 km/h - 52 kts - 60 MPH.

CLIMB SPEED

Full throttle power IAS = 101 km/h - 55 kts - 63 MPH.

- Between take-off and an altitude of 6000 ft, the average rate of climb is 1.4 m/s (275 ft/min.).
- Do not let down with power off and do not exceed 225 km/h - 121 kts
 - 140 MPH IAS.

GLIDER TOWING INSTRUCTION PLACARD

This placard which is located on the cabin LH side near the pilot shows the following indications :

- Maximum weight of towed glider : 500 kg
- Maximum weight of towing aircraft : 820 kg
- Normal towing indicated airspeed : 101 km/h - 55 kts - 63 MPH
- Minimum towing indicated airspeed : 88 km/h - 48 kts - 55 MPH

FERNANDEZ TYPE SKIS

1. BREAKDOWN OF CES. RA. 172. 820 EQUIPMENT

This equipment consists of the following :

- 2 Main skis 5000 HL
- 1 Nose ski T 48-00 ou T 48-LRS
- 1 Actuating pump unit 301-00
- 1 Set of adapters
- 1 Rear view mirror on LH wing strut
- 1 Operating instruction placard in cabin near the pilot

Equipment weight 50 kg

NOSE SHOCK-STRUT

- Maximum inflation pressure : 3.8 bar - 55 PSI
- Minimum inflation pressure : 3.1 bar - 45 PSI

2. OPERATION LIMITATIONS

- SPEED LIMITATION

- Maximum permissible indicated airspeed with skis is
233 km/h - 126 kts - 145 MPH.
- Maximum ski operating indicated airspeed is 161 km/h -
87 kts - 100 MPH.

- OPERATING LIMITATION

The use of this aircraft is authorized only on airfields covered with snow or not and on horizontal platforms (with special features : frozen lake, etc. . .) to the exclusion of snow-covered medium altitude altiports (2000 m) and glaciers.

3. EMERGENCY PROCEDURES

Refer to Section 3 - Pages 3-1 thru 3-7

4. NORMAL CHECKS AND PROCEDURES

PREFLIGHT INSPECTION

- MAIN SKIS

- Check skis for external condition.
- Check cables and attaching snap hooks.
- Check elastic cords (from time to time, rotate elastic cords 1/4 turn on their rollers).
- Inspect lines.

- NOSE SKI

- Same checks as for main skis.
- Check nose shock-strut inflation pressure.

OPERATION WITH WHEELS

- TAXI INSTRUCTION

Since the nose wheel is rigidly interconnected with the rudder pedals, it is recommended not to apply the brakes to turn on the ground.

It is preferable to gradually push on the lower part of the rudder pedal to avoid wheel brake application ; braking a wheel will cause the aircraft to turn with a radius smaller than that allowed by the nose wheel deflection and place undue lateral stresses on the nose gear leg.

- BEFORE TAKE-OFF

Check that the selection pointer knob is in the "WHEELS" position and cycle the pump once or several times until it is hard to operate.

SKI EXTENSION IN FLIGHT

Extension indicated airspeed : 129 to 161 km/h - 70 to 87 kts - 80 to 100 MPH.

Set selection pointer knob to "SKIS" position and cycle the pump until it is hard to operate (about 30 to 40 pump strokes are required).

Correct extension of the skis can be checked from the cabin.

NOTE

For long flights and specially in turbulent atmosphere, it is recommended to select the "SKIS" position.

Retraction and extension of the skis in flight should be accomplished at an indicated airspeed between 129 and 161 km/h -70 and 87 kts- 80 and 100 MPH.

OPERATION WITH SKIS

- BEFORE TAKE-OFF

Check that the selection pointer knob is in the "SKIS" position and cycle the pump once or several times until it is hard to operate.

- TAKE-OFF FROM SNOW-COVERED SURFACE

It is recommended to select 20° flaps and pull the aircraft nose up immediately upon power application so as to clear the nose ski from snow as quickly as possible. As the aircraft lightens, ease the stick forward but do not allow the nose ski to contact snow again.

In the case of a critical take-off, select full flaps when pulling the aircraft off ground.

- LANDING IN DEEP SNOW

If it is desired to pivot the aircraft on its skis on deep snow, this maneuver should be accompanied with a forward or backward movement.

5. PERFORMANCE

Refer to Section 5, Pages 5-1 thru 5-14, allowing for a slight performance data reduction due to the ski equipment.

6. USE AND SERVICING

- CHANGEVER FROM WHEELS TO SKIS ON HARD GROUND

Changeover from wheels to skis on hard ground by means of the hydraulic control only is not recommended ; this operation should be accompanied with a forward motion of the aircraft to facilitate aircraft lifting on its skis. This motion may be produced either by a power pulling action or by personnel pushing the aircraft.

- MOVING AIRCRAFT OUT OF A HANGAR ON A SNOW-COVERED AIRFIELD

Roll the aircraft to hangar threshold, form a carpet of snow under the aircraft skis and place the aircraft on its skis over the snow carpet. Once this operation is completed, it will be easy to move the aircraft out of the hangar by sliding it on its skis.

PLACING THE AIRCRAFT IN "WHEELS" POSITION ON SNOW
IS TO BE PROHIBITED

- MOVING AIRCRAFT FROM SNOW-COVERED STRIP TO DRY HANGAR

Move aircraft to hangar threshold and in order to avoid damaging the bottom surface of the skis prepare with a shovel three snow tracks six feet long and corresponding to ski track.

Move aircraft over snow tracks by pushing it or by using a power pulling action.

When the aircraft wheels are inside the hangar, set the pump selector to "WHEELS" and operate the pump 30 to 40 times ; the aircraft will go on its wheels by itself.

SKI ADJUSTMENT

- MAIN SKI ADJUSTMENT

(This adjustment is made in "WHEELS" position)

The heel of the main skis should in no case trail on the ground. Adjust the heel at 5 or 6 cm from ground by means of the aft cable.

To make this adjustment, only lengthen or shorten the aft cable with the adjusting cable clamp.

- NOSE SKI ADJUSTMENT

Adjustment in "WHEELS" position

This adjustment is to be made on flat ground.

The sole of the ski must be parallel to ground. The ski may have a 1 to 2° maximum nose up attitude but its heel should in no case touch the ground.

Adjustment in "SKIS" position

The nose section of the aircraft will be raised until the nose ski is off ground.

The nose ski sole should have an attack incidence of 5 to 6° relative to the aircraft longitudinal axis.

The nose ski deflection should be + 10°.

SERVICING

The skis are to be cleaned with a water and detergent solution.

The top surface of the skis will be waxed to prevent snow sticking and the sole will be rubbed with 400 grit wet sanding paper to improve running on snow.

The fluid used in the hydraulic system is Shell fluid No. 4.

ARC NAV-O-MATIC 300 AUTOMATIC PILOT

1. GENERAL

This is a one-axis (roll) autopilot with heading coupling capabilities. The major components of the autopilot are as follows :

- A control and amplifier unit.
- A navigation coupler.
- A roll actuator.
- A vacuum-driven directional gyro.
- A turn coordinator.
- A vacuum source.
- Mechanical parts.

2. OPERATION LIMITATIONS

The automatic pilot must not be used for take-off and landing.

3. EMERGENCY PROCEDURES

In case of a malfunction, the autopilot can be easily overpowered by actuating the manual flight controls. The autopilot must then be disengaged by turning the three-position selector switch to "OFF".

4. NORMAL PROCEDURES

TAKE-OFF

Set three-position selector switch to "OFF".

CRUISE

- (1) Manually trim the aircraft for straight and level flight.
- (2) Pull out "PULL-TURN" knob and leave in detent.
- (3) Set three-position selector switch to "HEADING".
- (4) Laterally trim the aircraft using the lower control on the control unit.

MAKING TURNS WITH AUTOPILOT ENGAGED

- (1) Set three-position selector switch to "HEADING" or "OMNI".
- (2) Pull out "PULL-TURN" knob and rotate to either "L" (left) or "R" (right) position depending on the desired turn direction.

NOTE

Placing the "PULL-TURN" knob in the full "L" or "R" position establishes a standard rate turn.

- (3) Rotate "PULL-TURN" knob to the center position and place it in detent to resume straight and level flight.
Push in "PULL-TURN" knob to switch back to pre-selected function.

MAGNETIC HEADING HOLD FUNCTION

- (1) Pull out "PULL-TURN" knob and leave in detent.
- (2) Select desired heading using the heading selector on the directional gyro.
- (3) Set three-position selector switch to "HEADING".
- (4) Push in "PULL-TURN" knob ; the aircraft will turn to the selected heading.
- (5) Check that directional gyro heading is aligned with the magnetic compass and reset if necessary.

NOTE

If aircraft actual heading slightly differs from the selected heading, check that :

- (a) The aircraft is correctly trimmed laterally.
- (b) The selected heading is correctly set on the directional gyro.

OMNI COUPLING FUNCTION

- (1) Set the selected station frequency.
- (2) Pull out "PULL-TURN" knob and leave in detent.
- (3) Select desired heading on the Omni indicator.
- (4) Select the same heading using the heading selector on the directional gyro.
- (5) Set three-position selector switch to "OMNI".
- (6) Push in "PULL-TURN" knob ; the aircraft will intercept and track the selected Omni radial.

NOTE

- (a) The interception will start at an aircraft position within $\pm 30^\circ$ from the selected Omni radial.

- (b) Drift correction is limited to 10°. For more important drift values, slightly alter heading using the heading selector on the directional gyro.
- (7) Check that directional gyro heading is aligned with the magnetic compass and reset if necessary.
- (8) When approaching the Omni station, set three-position selector switch to "HEADING". If necessary, correct the drift using the heading selector on the directional gyro and check the directional gyro setting.

NOTE

If the three-position selector switch is left in the "OMNI" position, heading hold function will be inoperative and the aircraft heading erratic.

F172 AIRCRAFT SKYDIVING KIT

1. BREAKDOWN OF CES. RA. 172. 40 EQUIPMENT

- A copilot control wheel quick-release system.
- A thinner pilot's seat back.
- A skydiver seat with head rest and seat belt.
- A rear bench-type seat with dorsal strap.
- Two static line tie-down points on front feet of rear bench-type seat.
- A foothold with safety basket.
- A handrail on RH door frame.
- A baffle on RH door front doorpost.
- A tassel on top of RH door front doorpost.
- A static line protection tube on RH door rear doorpost.
- A RH side protection plate at rear bench-type seat.
- An upper door protection plate for aircraft models prior to 1971.
- A hangrip on RH wing strut.

2. OPERATION REQUIREMENTS

MAXIMUM GROSS WEIGHT FOR TAKE-OFF AND LANDING

Normal Category Maximum Gross Weight Approved in this Flight Manual : 1043 kg

CENTER OF GRAVITY RANGE LIMITS

	<u>Forward Limit</u>	<u>Rear Limit</u>
at 1043 kg	+ 0.98 m	+ 1.20 m
at 885 kg or less	+ 0.89 m	+ 1.20 m

LOADING LIMITS

Number of Occupants :

Front Seats : 2

Rear Seats : 2

Minimum Crew : 1

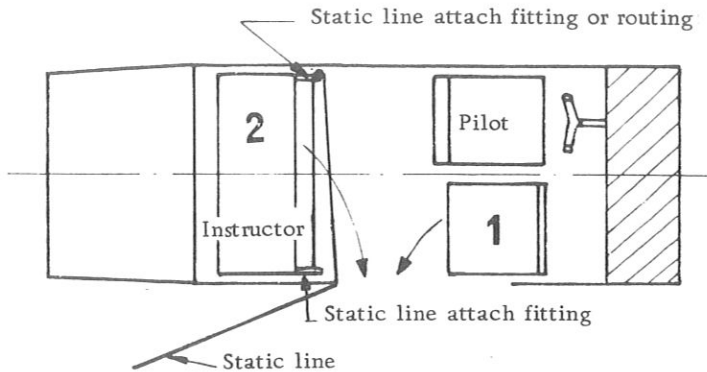

Depending on their length, static lines are attached to either fitting on front feet of skydiver rear bench-type seat.

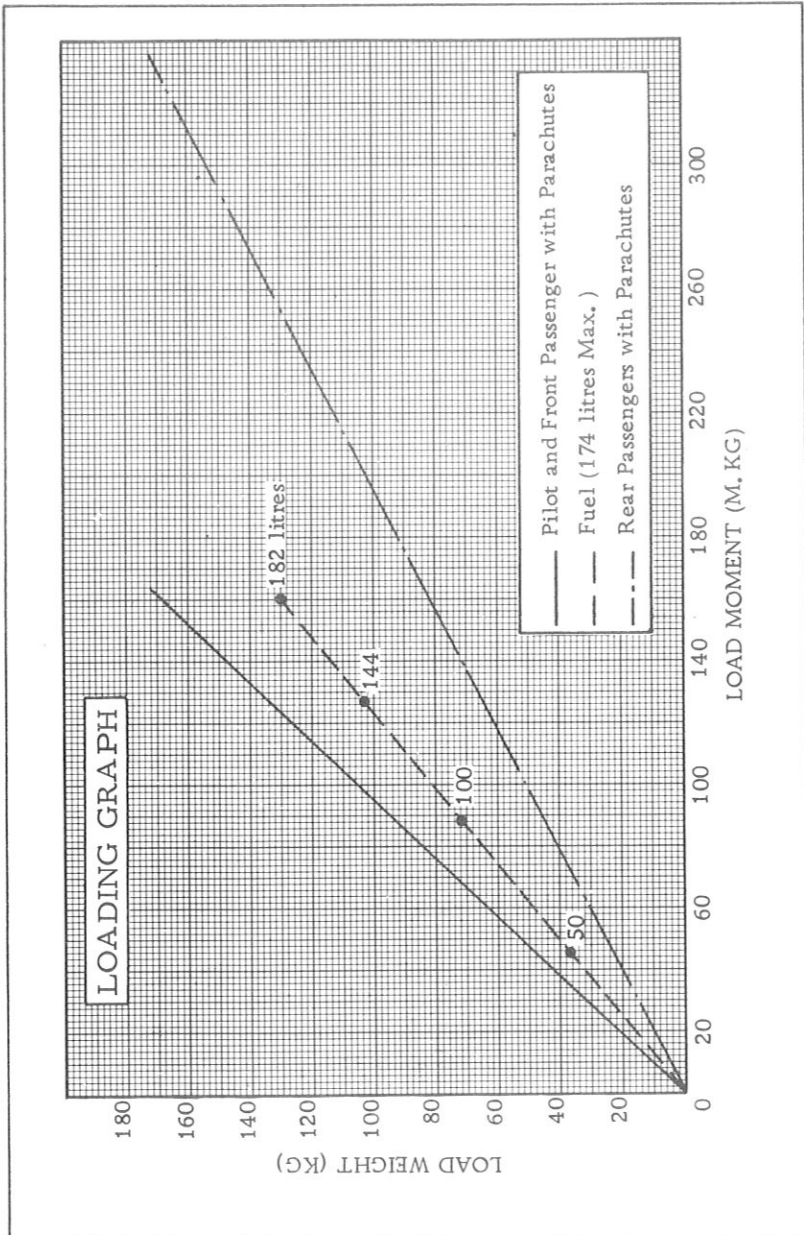

WEIGHT AND BALANCE LIMITS

SAMPLE LOADING PROBLEM	SAMPLE AIRPLANE		YOUR AIRPLANE	
	Weight kg	Moment m. kg	Weight kg	Moment m. kg
1. Licensed Empty Weight + Undrainable Oil + Undrainable Fuel	625	581		
2. Pilot With Parachute + 1st Skydiver	185	175		
3. Instructor With Parachute + 2nd Skydiver	200	390		
4. Fuel	33	41		
5. TOTAL WEIGHT AND MOMENT	1043	1170		
<p><u>NOTE</u> : Locate this point (1043 and 1170) on the center of gravity moment envelope, page 4-4 of this Flight Manual, and since this point falls within the envelope, the loading is acceptable.</p>				

3. OPERATING DETAILS

REMOVE

Cabin RH door
Copilot seat
Rear passenger bench-type seat
Copilot control wheel
Main gear RH wheel fairing (if installed)
Pilot seat back,

INSTALL

CES. RA. 172. 40 equipment described in chapter 1

NOTE

Check that static line does not interfere with any installation outside the fuselage.

4. SKYDIVING INSTRUCTIONS

Skydivers will leave the airplane in the sequence shown in the figure in chapter 2 :

- 1st skydiver - 2nd skydiver - Instructor

STATIC LINE JUMP

Operating Check List

- Grasp tassel with left hand,
- Bend down to maximum with knees bent,
- Grasp wing strut handgrip with right hand,
- Lay feet on foothold, with both hands on wing strut handgrip.

Jump head first with 1/8 of a turn rotation to the right.

DELAYED OPENING JUMP

Instructions are similar to those applicable for static line jump procedure. Dropping of three skydivers is possible during a single pass.

AIRCRAFT INDICATED AIRSPEED DURING SKYDIVING OPERATIONS

Aircraft indicated airspeed will not exceed 161 km/h - 87 kts - 100 MPH during skydiving operations.

Wing flaps may be extended 10° if necessary.

NOTE

In addition to his usual functions, the instructor should pay extreme attention to the routing of the static lines which may pass between the skydiver's dorsal parachute and his back. The instructor should pull back the static lines underneath the rear bench-type seat after each pass.

The second skydiver on the rear bench-type seat should not rest on the pilot's seat back.

If weight and balance limit is in accordance with the table on page 6-1.23, no load should be placed aft of the skydiver rear bench-type seat.

BADIN CROUZET RG10B AUTOMATIC PILOT + DIRECTIONAL GYRO COUPLING + OMNI COUPLING

1. BREAKDOWN OF CES, RA, 172, 770 OPTION

A. BADIN CROUZET RG10B Automatic Pilot

This automatic pilot is intended for stabilization or control of the aircraft in roll and yaw through the roll control system.

The major components are as follows :

- A flight controller.
- A roll/yaw sensor.
- An air distributor.
- Two aileron control air-driven actuators.
- A vacuum source.
- Mechanical parts.

B. Directional Gyro Coupling and Omni Coupling

The above automatic pilot may be supplemented with the following equipment :

- A vacuum-driven directional gyro.
- A "HDG-VOR" navigation coupler.

2. OPERATION LIMITATIONS

The automatic pilot must not be used for take-off and landing.

Minimum operation altitude : 200 m - 656 ft.

3. EMERGENCY PROCEDURES

Automatic Pilot Failure

- Take over manual control of the aircraft.
- Set autopilot "ON-OFF" switch to "OFF".
- Close "VIDE P, A, " ("A, P. VACUUM") valve on the instrument panel.

Electrical Failure

- Any electrical failure will result in the failure of the automatic pilot and may be cause for residual forces to be overpowered.
- Apply the above procedure.

4. NORMAL PROCEDURES

Before Take-Off

- Set "TURN" and "TRIM" knobs to neutral.
- "STAB-HDG" selector switches - "STAB".
- Autopilot "ON-OFF" switch - "OFF".
- "VIDE P, A, " ("A, P. VACUUM") valve - "OUVERT" ("OPEN").
- Suction gage - Check (4.6 to 5.4 inches of mercury).

Take-Off

- Autopilot "ON-OFF" switch - "OFF".

Automatic Pilot Engagement

- While holding the control wheel, set the following switches as follows :
 - "STAB-HDG" selector switch - "STAB".
 - Autopilot "ON-OFF" switch - "ON".
- Release the control wheel
 - Adjust "TRIM" knob for zero rate.

- Maintain a steady climb angle with the manual flight controls without counteracting the transverse movements induced by the automatic pilot.
- To make turns, rotate "TURN" knob to "L" or "R" according to the desired turn direction.
- Roll-out : Return "TURN" knob to neutral.
- "TRIM" knob must be readjusted from time to time to compensate for aerodynamic asymmetry.

NOTE

The automatic pilot is operative as soon as engaged .

Directional Gyro Coupling

- Select desired heading on the directional gyro compass card (aligned with magnetic compass heading).
- Set "HDG-VOR" selector switch to "HDG".
- Set "STAB-HDG" selector switch to "HDG" - The aircraft turns to the selected heading.
- "STAB-HDG" selector switch need not be set to "STAB" to change heading or to reset the directional gyro.

Omni Coupling Function

- Set the selected station frequency at the Omni control unit.
- Select desired heading on the directional gyro compass card and the Omni indicator.
- Set "HDG-VOR" selector switch to "VOR".
- Check "STAB-HDG" selector switch is set to "HDG".
- The selected heading is automatically maintained or corrected.

NOTE

If the aircraft is subjected to strong crosswind conditions, it is recommended to allow for a certain amount of drift upon heading selection on the directional gyro compass card, not altering the course selected on the Omni indicator.

FLOATPLANE OPTION

INTRODUCTION

This supplement, written especially for operators of the REIMS/CESSNA Model F172 floatplane, provides information not found in the F172 Flight Manual. It contains procedures and data required for safe and efficient operation of the floatplane.

Information contained in the Flight Manual for the F172 landplane, which is the same as that for the floatplane, is not repeated in this supplement.

The information provided here was compiled from tests with an airplane equipped with Edo Model 89A 2000 floats.

1. DESCRIPTION

The REIMS/CESSNA Model F172 floatplane is identical to the landplane with the following exceptions :

- (1) Floats, incorporating a water rudder steering system, replace the landing gear.

A water rudder retraction handle, connected to the dual water rudders by cables and springs, is located on the cabin floor.
- (2) Additional fuselage structure is added to support the float installation.
- (3) An additional structural "V" brace is installed between the top of the front door posts and the cowl deck.
- (4) The airplane has additional corrosion-proofing and stainless steel control cables.
- (5) Wing flap limit switches are adjusted to restrict the maximum flap travel to 30°.
- (6) Interconnect springs are added between the rudder and aileron control systems.
- (7) The fuel strainer installation is modified for floatplane use.
- (8) The standard propeller is replaced with a propeller of larger diameter (80 in. - 2.03 m) and flatter pitch, part number McCauley 1A175/ATM8042 or 1A175/ETM8042. The standard propeller spinner is modified.
- (9) Hoisting provisions are added to the top of the fuselage.
- (10) Floatplane placards are added.

- (11) Fueling steps and assist handles are mounted on the forward fuselage, and steps are mounted on the wing struts to aid in refueling the airplane.

WATER RUDDER STEERING SYSTEM

The retractable water rudders are mounted at the aft end of each float and are connected by a system of cables and springs to the airplane rudder pedals. When the water rudders are extended, normal operation of the rudder pedals moves the water rudders to provide steering control for taxiing.

A water rudder retraction handle, located on the cabin floor between the front seats, is used to manually raise and lower the water rudders. During take-off, in flight, and landing, the retraction handle is normally secured on the stowage hook located on the cabin floor just aft of the control pedestal. With the handle in this position, the water rudders are up. When the handle is removed from the stowage hook and allowed to retract full aft, the water rudders extend to the full down position for taxiing.

2. LIMITATIONS

"Normal Category Only"

INDICATED AIRSPEED LIMITATIONS

	km/h	fts	MPH
Vne (Never Exceed Speed)	295	159	183
Vno (Maximum Structural Cruising Speed)	237	128	147
Vfe (Maximum Speed, Flaps Extended)	158	86	99
Vp (Maneuvering Speed)	180	97	112

FLIGHT MANEUVERING LOAD FACTORS AT GROSS WEIGHT OF 1007 KG

Flaps Up	+ 3.8
	- 1.52
Flaps Down	+ 3.0

MAXIMUM GROSS WEIGHT FOR TAKE-OFF AND LANDING

Take-Off :	1007 kg
Landing :	1007 kg

LOADING LIMITS

WEIGHT AND BALANCE

The following information will enable you to operate your floatplane within the prescribed weight and center of gravity limitations.

In figuring your loading problems, be certain that you use the Licensed Empty Weight of your particular floatplane as shown on its Weight and Balance Data Sheet. This sheet, plus an Equipment List, is included with each floatplane as it leaves the factory. When the floats have been installed by anyone other than the factory, the aircraft log book (Repair and Alteration Form) must be consulted for proper weight and balance information.

The loading instructions given in the Flight Manual for the landplane should be used as a guide when figuring floatplane weight and balance problems. In conjunction with these instructions, use the Sample Problem, Loading Graph, and Center of Gravity Moment Envelope in this supplement.

SAMPLE LOADING PROBLEM	SAMPLE AIRPLANE		YOUR AIRPLANE	
	Weight kg	Moment m. kg	Weight kg	Moment m. kg
1. Licensed Empty Weight (Sample Airplane)	719.20	728		
2. Oil (8 qts. - 7.6 litres - The weight of full oil may be used for all calculations)	6.80	- 3.40	6.80	- 3.40
3. Fuel (Standard - 38 US Gal. at 6 Lbs/Gal.)	103	126		
Fuel (Long Range - 48 US Gal. at 6 Lbs/Gal.)				
4. Pilot and Front Passenger	154	145		
5. Rear Passengers				
6. Baggage or Passenger on Child's Seat	24	57.40		
7. TOTAL WEIGHT AND MOMENT	1007	1053		
8. Locate this point (1007 and 1053) on the center of gravity moment envelope, and since this point falls within the envelope, the loading is acceptable.				

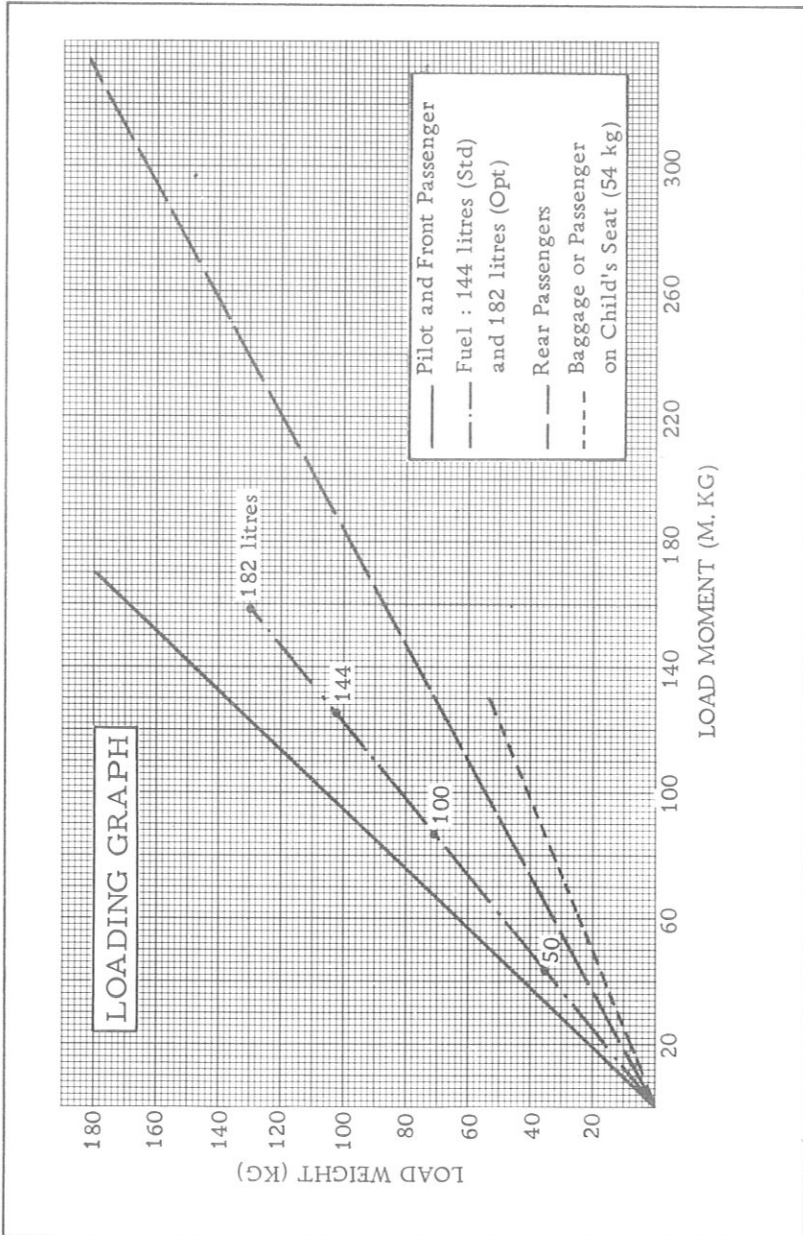

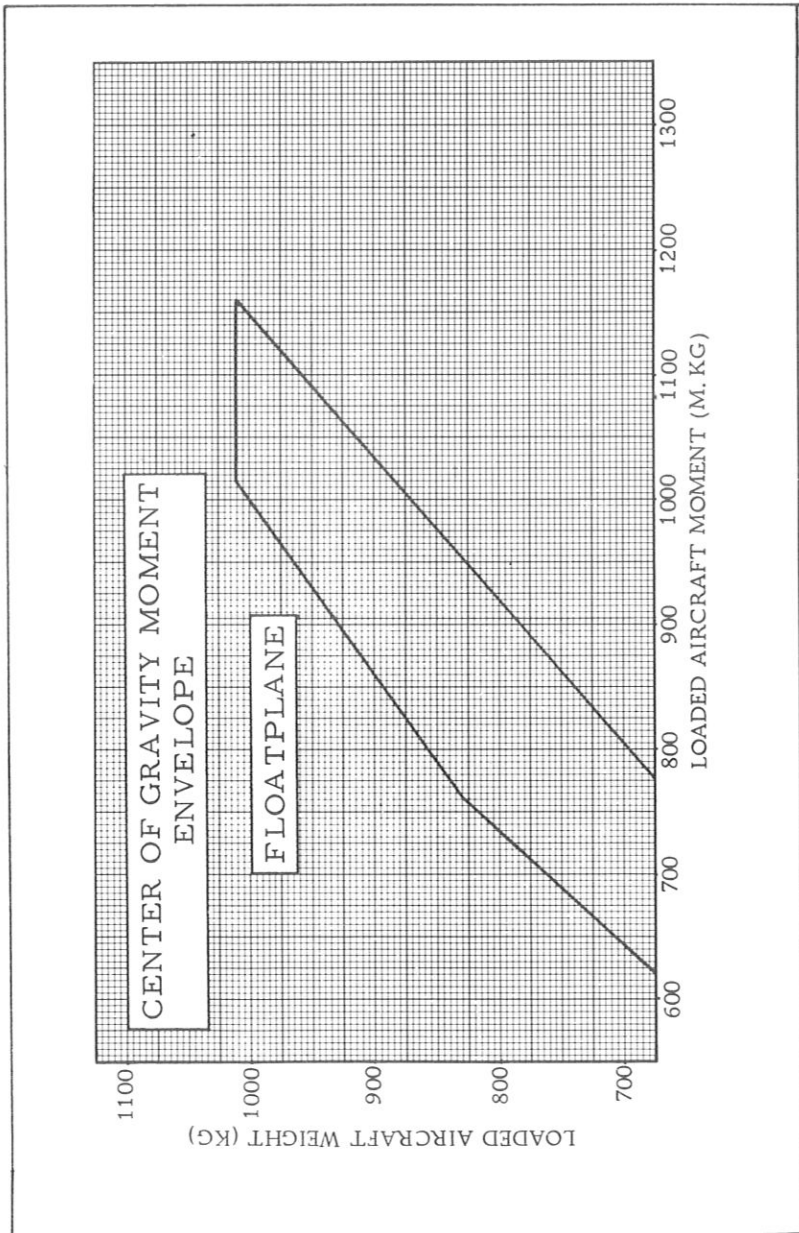

3. EMERGENCY PROCEDURES

Refer to Section 3, page 3-1 thru 3-7.

4. NORMAL CHECKS AND PROCEDURES

BEFORE ENTERING THE FLOATPLANE

- (1) Inspect the floats for dents, cracks, scratches, etc.
- (2) Remove the cover plates and inspect the floats for water, removing accumulation with a sponge or pump. Reinstall cover plates, tightening only enough for a snug fit.

BEFORE STARTING ENGINE

- (1) Operate and visually check water rudders for proper retraction and rudder action.
- (2) Water Rudders - Down for taxiing (retraction handle removed from stowage hook).

TAKE-OFF

- (1) Water Rudders - Up (retraction handle secured on stowage hook).
- (2) Set wing flaps 0° to 10° (preferably 10°).
- (3) Hold the control wheel full back and advance the throttle slowly.
- (4) Place the airplane in a planing attitude (on the step) by slowly moving the control wheel forward when the bow wave moves aft of the wing strut position.

- (5) As the airplane accelerates, apply light control wheel back pressure and allow the airplane to fly off smoothly.

NOTE

To reduce take-off water run, the technique of raising one float out of the water may be used. This procedure is described on page 6-1.40 under "Minimum Run Take-Off".

- (6) Climb out at IAS = 104-121 km/h - 57-65 kts - 65-75 MPH with flaps 10° or 113-129 km/h - 61-69 kts - 70-80 MPH with flaps up (refer to Take-Off Data chart on page 6-1.49 for optimum climb-out speeds with flaps 10°).

CLIMB

- (1) Wing Flaps - Retracted.
- (2) Indicated Airspeed - 111 to 127 km/h - 60 to 69 kts - 69 to 79 MPH.

NOTE

If a maximum performance climb is necessary, use speeds shown in the "Maximum Rate-of-Climb Data" chart, page 6-1.51.

BEFORE LANDING

- (1) Water Rudders - Up.
- (2) Maintain an indicated airspeed between 104 and 121 km/h - 57 and 65 kts - 65 and 75 MPH with wing flaps extended.

LANDING

- (1) Touchdown in conventional manner at desired wing flap setting.
- (2) Maintain full up elevator as floatplane decelerates to taxi speed.

IMPORTANT

With forward loading, a slight nose-down pitch may occur if the elevator is not held full up as floatplane comes down off step.

AFTER LANDING

- (1) Water Rudders - Down.

TAXIING

Taxi with water rudders down. It is best to limit the engine speed to 1000 RPM for normal taxi because water piles up in front of the float bow at higher engine speeds. Taxiing with higher engine RPM may result in engine overheating and will not appreciably increase the taxi speed.

For minimum taxi speed in close quarters, use idle RPM with full carburetor heat and a single magneto. This procedure is recommended for short periods of time only.

Although taxiing is very simple with the water rudders, it is sometimes necessary to "sail" the floatplane in close quarters. In addition to the normal flight controls, the wing flaps, cabin doors, and water rudders will aid in "sailing".

To taxi great distances, it may be advisable to taxi on the step with the water rudders retracted. Turns on the step may be made with safety providing they are not too sharp and if ailerons are used to counteract the overturning tendency.

TAKE-OFF

Normal Take-Off

The use of 10° flaps throughout the take-off run is recommended (refer to Take-Off Data chart on page 6-1.49 for take-off distances).

Apply full throttle smoothly and hold the control wheel full back. Watch the point where the bow wave leaves the float, and move the control wheel forward slowly as this point moves aft of the wing strut. Slow control movement and light control pressures produce the best results. Attempts to force the airplane into the planing attitude will generally result in loss of speed and delay in getting on the step. The airplane will assume a planing attitude which permits acceleration to take-off indicated airspeed : 82 to 98 km/h - 44 to 53 kts - 51 to 61 MPH at which time the airplane will fly off smoothly.

Minimum Run Take-Off

To shorten the take-off run, the following procedure is recommended : With the airplane in the planing position with flaps down 10°, allow the indicated airspeed to build up to about 66 km/h - 36 kts - 41 MPH, at which speed one float can be raised out of the water by slowly applying full aileron. When one float leaves the water, apply slight elevator back pressure to complete the take-off. Care must be taken to stop the rising wing as soon as the float is clear of the water, and in crosswinds, raise only the downwind wing. With one float out of the water, the airplane accelerates to take-off speed almost instantly.

If porpoising is encountered while on the step, apply additional control wheel back pressure to correct the excessively nose-low attitude.

Crosswind Take-Off

Start the take-off run with flaps up and the water rudders extended for better directional control. Flaps are lowered to 10° and the water rudders

retracted when the airplane is on the step ; the remainder of the take-off is normal. If the floats are lifted from the water one at a time, the downwind float should be lifted first.

Enroute Climb

For detailed data, refer to the Maximum Rate-Of-Climb Data chart on page 6-1.51. Normal climbs are conducted at IAS = 111-129 km/h - 60-69 kts - 69-80 MPH with flaps retracted. The maximum rate-of-climb indicated airspeed range from 120 km/h - 65 kts - 75 MPH at sea level to 103 km/h - 56 kts - 64 MPH at 10,000 feet at gross weight. If an enroute obstruction dictates the use of a steep climb angle, climb at IAS = 95 km/h - 51 kts - 59 MPH with flaps retracted.

NOTE

Steep climbs at low speeds should be of short duration to improve engine cooling.

Cruise

True airspeed, range and endurance figures are shown on the Cruise and Range Performance chart on page 6-1.46.

Landing

Normal landings can be made power on or power off using approach indicated airspeeds of 119-135 km/h - 64-73 kts - 74-84 MPH with flaps up and 104-121 km/h - 57-65 kts - 65-75 MPH with flaps down.

Glassy Water Landing

With glassy water conditions, flaps should be set at 0° to 20° and enough power used to maintain a sink rate of about 200 feet per minute.

The airplane should be flown onto the water at this sink rate with no flare since the height above smooth water is difficult to judge. Power should be reduced and back pressure increased upon contacting the surface.

Crosswind Landing

The wing-low slip method should be used with the upwind float contacting first.

5 - PERFORMANCE

The tables appearing on the following pages will be useful in flight planning. Nevertheless, it will be advisable to plan on a safety margin concerning the fuel reserve at arrival, since the data given does not take into account the effects of wind, navigational errors, pilot technique, run-up, climb, atmospheric turbulence and other undetermined variables which may cause range to vary by 10 % or more.

PERFORMANCE

GROSS WEIGHT

SPEED :

Top Speed at Sea Level

Cruise, 75 % Power at 7500 ft

RANGE :

Cruise, 75 % Power at 7500 ft
38 US Gal. (144 l), No Reserve

Cruise, 75 % Power at 7500 ft
48 US Gal. (182 l), No Reserve

Optimum Range at 10,000 ft
38 US Gal. (144 l), No Reserve

Optimum Range at 10,000 ft
48 US Gal. (182 l), No Reserve

RATE OF CLIMB AT SEA LEVEL

SPECIFICATIONS

1007 kg

182 km/h - 113 MPH

180 km/h - 112 MPH

845 km

4.7 hrs

180 km/h - 112 MPH

1060 km

5.9 hrs

180 km/h - 112 MPH

925 km

5.8 hrs

159 km/h - 99 MPH

1165 km

7.3 hrs

159 km/h - 99 MPH

3.63 m/s - 715 fpm

<u>SERVICE CEILING</u>	3660 m - 12,000 ft
<u>TAKE-OFF :</u>	
<u>Water Run</u>	494 m
Total Distance Over 50-Ft Obstacle	728 m
<u>ALIGNING :</u>	
<u>Water Run</u>	180 m
Total Distance Over 50-Ft Obstacle	410 m
<u>EMPTY WEIGHT (Approximate)</u>	667 kg
<u>WING LOADING</u>	62 kg/m ²
<u>POWER LOADING</u>	9.35 kg/kW
<u>TOTAL FUEL CAPACITY :</u>	
"Standard" Tanks	159 litres - 42 US Gal.
Optional "Long Range" Tanks	197 litres - 52 US Gal.
<u>OIL TANK CAPACITY</u>	7.5 litres - 8 qts
<u>PROPELLER : Fixed Pitch (Diameter)</u>	2.03 m
<u>ENGINE : Lycoming engine 150 rated HP at 2700 RPM</u>	Type O-320 E2D - 112 kW

CRUISE PERFORMANCE

Lean Mixture - Standard Conditions

ALTITUDE m ft	RPM	% BHP	FUEL CONSUMPTION (PER HOUR) Litres	TAS km/h kts MPH			38 US GAL. (NO RESERVE)			48 US GAL. (NO RESERVE)				
							Endurance		Range		Endurance		Range	
							Hours	km	NM	Hours	km	NM		
Sea Level	2700	92	39	182	98	113	3.7	668	361	4.6	845	457		
	2600	83	34.8	176	95	109	4.1	725	392	5.2	918	496		
	2500	74	30.6	168	90	104	4.7	780	421	5.9	990	535		
	2400	66	27.6	159	86	99	5.2	837	452	6.6	1052	569		
	2300	58	25	151	82	94	5.7	870	470	7.2	1092	590		
	2200	52	23.4	142	76	88	6.2	876	473	7.8	1110	600		
	2100	47	22.3	132	71	82	6.5	853	460	8.2	1078	582		
762 2500	2700	86	36	182	98	113	4.0	725	391	5.0	908	490		
	2600	77	32.2	174	94	108	4.5	780	421	5.6	982	530		
	2500	69	28.7	168	90	104	5.0	837	452	6.3	1052	569		
	2400	61	26.1	158	85	98	5.5	870	470	7.0	1100	594		
	2300	55	24.2	150	81	93	6.0	893	482	7.5	1125	608		
	2200	50	22.7	138	75	86	6.3	876	473	8.0	1110	600		
1524 5000	2700	80	33.6	180	97	112	4.3	780	421	5.4	982	530		
	2600	72	29.8	174	94	108	4.8	829	447	6.1	1052	569		
	2500	64	26.8	166	89	103	5.3	876	473	6.7	1110	600		
	2400	57	25	156	84	97	5.8	902	487	7.3	1133	612		
	2300	52	23.4	147	79	91	6.1	893	482	7.8	1125	608		
2286 7500	2700	75	30.6	180	97	112	4.7	845	457	5.9	1062	573		
	2600	67	28	173	93	107	5.1	885	478	6.5	1118	603		
	2500	60	25.7	163	88	101	5.6	908	490	7.1	1150	567		
	2400	55	24.2	153	83	95	6.0	908	490	7.5	1150	567		
	2300	51	23.1	138	75	86	6.3	870	470	7.9	1092	590		
3048 10000	2700	69	29.1	179	96	111	5.0	885	478	6.3	1118	603		
	2600	63	26.5	169	91	105	5.4	918	496	6.9	1158	572		
	2500	57	25	168	86	99	5.8	925	499	7.3	1165	629		
	2400	53	23.4	145	78	90	6.1	885	478	7.7	1118	603		

Maximum recommended cruise is done at 75 % power.

AIRSPEED CORRECTION TABLE

FLAPS UP											
IAS	km/h	74	93	111	130	148	167	185	204	222	241
CAS	km/h	79	96	113	132	148	167	183	200	219	237
IAS	kts	40	50	60	70	80	90	100	110	120	130
CAS	kts	42	52	61	71	80	90	99	108	118	128
IAS	MPH	46	58	69	81	92	104	115	125	138	150
CAS	MPH	48	60	70	82	92	104	114	124	136	147
FLAPS DOWN											
IAS	km/h	74	93	111	130	148	167				
CAS	km/h	74	93	109	130	148	169				
IAS	kts	40	50	60	70	80	90				
CAS	kts	40	50	59	70	80	91				
IAS	MPH	46	58	69	81	92	104				
CAS	MPH	46	58	68	81	92	105				

STALL SPEEDS				
POWER OFF	ANGLE OF BANK			
	0°	20°	40°	60°
MAXIMUM GROSS WEIGHT 1007 kg CONDITIONS	89 km/h 48 kts 55 MPH	92 km/h 50 kts 57 MPH	101 km/h 55 kts 63 MPH	125 km/h 68 kts 78 MPH
FLAPS UP	84 km/h 45 kts 52 MPH	87 km/h 47 kts 54 MPH	95 km/h 51 kts 59 MPH	119 km/h 64 kts 74 MPH
FLAPS 30°	80 km/h 43 kts 50 MPH	84 km/h 45 kts 52 MPH	92 km/h 50 kts 57 MPH	114 km/h 62 kts 71 MPH

TAKE-OFF DISTANCE				FLAPS 10°					
GROSS WEIGHT	IAS 15 m	HEAD WIND		AT SEA LEVEL AND + 15°C		AT 762 M - 2500 FT AND + 10°C		AT 1524 M - 5000 FT AND + 5°C	
		km/h	kts	Water Run m	Total to Clear 15 m Obs m	Water Run m	Total to Clear 15 m Obs m	Water Run m	Total to Clear 15 m Obs m
817	90 km/h	0		284	433	349	525	432	643
	49 kts	18.5	10	180	298	224	364	282	455
	56 MPH	37	20	98	185	125	230	163	293
907	95 km/h	0		374	557	462	685	578	857
	51 kts	18.5	10	240	389	305	485	388	617
	59 MPH	37	20	137	248	178	316	233	410
1007	100 km/h	0		494	728	617	917	783	1182
	54 kts	18.5	10	328	520	418	662	536	868
	62 MPH	37	20	194	342	253	443	336	596

NOTE : Increase the distance by 10 % for each 15°C (25°F) increase in temperature above standard for the particular altitude.

LANDING DISTANCE		FLAPS LOWERED 30° POWER OFF					
		AT SEA LEVEL AND + 15°C		AT 762 M - 2500 FT AND + 10°C		AT 1524 M - 5000 FT AND + 5°C	
GROSS WEIGHT	APPROACH SPEED	Water Run	Total to Clear 15 m Obs	Water Run	Total to Clear 15 m Obs	Water Run	Total to Clear 15 m Obs
kg		m	m	m	m	m	m
1010	105 km/h 56.5 kts 65 MPH	180	410	189	433	200	455

NOTE : Decrease distances shown by 10 % for each 5 kts (9.3 km/h) headwind.

MAXIMUM RATE OF CLIMB DATA									
GROSS WEIGHT	AT SEA LEVEL AND + 15°C			AT 1524 M - 5000 FT AND + 5°C			AT 3048 M - 10,000 FT AND - 5°C		
	IAS	Rate of Climb m/s	Fuel Used litres	IAS	Rate of Climb m/s	Fuel Used litres	IAS	Rate of Climb m/s	Fuel Used litres
817 kg	120 km/h 65 kts 75 MPH	5.0 m/s	3.8 litres	112 km/h 61 kts 70 MPH	3.5 m/s	9.1 litres	103 km/h 55.5 kts 64 MPH	2.0 m/s	15.5 litres
907 kg	122 km/h 66 kts 76 MPH	4.3 m/s	3.8 litres	114 km/h 62 kts 71 MPH	2.9 m/s	9.8 litres	105 km/h 56.5 kts 65 MPH	1.5 m/s	18.1 litres
1007 kg	124 km/h 67 kts 77 MPH	3.6 m/s	3.8 litres	116 km/h 63 kts 72 MPH	2.3 m/s	11.3 litres	106 km/h 57.5 kts 66 MPH	1.0 m/s	21.9 litres

NOTES : 1. Flaps up, full throttle, mixture leaned for smooth operation above 3000 ft (915 m).
2. Fuel used includes warm-up and take-off allowance.
3. For hot weather, decrease rate of climb 20 ft./mn (0.10 m/s) for each 10°F (5°C) above standard day temperature for particular altitude.

NAV-O-MATIC 200 A AUTOMATIC PILOT

1 GENERAL

This is a one-axis (roll) with VOR coupling (OPT) capabilities. The major components of the autopilot are as follows :

- An automatic pilot control head including a computer amplifier
- A roll actuator
- A turn coordinator
- A "VOR-LOC REVERSED" indicator light,

2 OPERATION LIMITATIONS

The automatic pilot must not be used for take-off and landing.

3 URGENCY PROCEDURES

In case of a malfunction, the autopilot can be easily overpowered by actuating the manual flight controls. The autopilot must then be switch off by pushing the A/P switch in the "OFF" position.

4 NORMAL PROCEDURES

BEFORE TAKE-OFF AND LANDING

On the autopilot control head,

1. "A/P" switch in the OFF position.
2. "BACK CRS" button - OFF position (See CAUTION note under NAV intercept, page 6.1.54.

CLIMB, CRUISE, DESCENT

Basic Directional Stability

1. Level wings.
2. On autopilot control head - "PULL TURN" control knob : Pull out and center in detent.

3. On autopilot control head - "A/P" switch in "ON" position.
4. On autopilot control head - Roll trim control.- Adjust for zero turn.
5. The wing level mode may be overridden with light control pressures to turn the aircraft to a new heading.

Command Turns

1. On autopilot control head - "PULL TURN" knob - Pull and rotate to give desired turn rate up to a maximum of a standard rate turn.

Heading Hold

On autopilot control head :

1. "DIR HOLD" button - Push in.
2. "PULL TURN" knob - Center in detent and push in when aircraft is on desired heading and wings are level.
3. Roll trim knob - Adjust for zero heading drift.

Nav Intercept (VOR/LOC)

On autopilot control head :

1. "PULL TURN" knob - Pull out and turn aircraft to heading parallel to desired course.
2. "NAV 1 or 2" selector switch - Select VHF receiver providing stable VOR/LOC navigation signal.

On VOR indicator :

3. Receiver OBS - Set in desired VOR course, if tracking omni.

On autopilot control head :

4. "NAV CAPT" button - Push in.
5. "HI SENS" button - Push in.
6. "BACK CRS" button - Push in if intercepting localizer front course outbound or back course inbound.

CAUTION

With "BACK CRS" button pushed in normal indications of CDI of selected receiver are reversed, even when the "A/P" switch is in the "OFF" position and regardless of frequency selected (Whether VOR or LOC), Glide slope indicator is not affected.

An amber light located on the upper, left hand portion of the instrument panel and labeled "VOR/LOC REVERSED" will illuminate when "BACK CRS" button is pushed in to indicate the course deviation indicator is reversed.

7. "PULL TURN" knob - Center in detent and push in when aircraft heading is parallel (within $\pm 5^\circ$) to desired course (the aircraft will then turn to a $45^\circ \pm 10^\circ$ intercept angle).
8. "NAV TRACK" button - Push in when CDI center and aircraft has turned to course heading.
9. "HI SENS" button - Push off when new omni course is established (leave in for localizer tracking).

NOTA

Good NAV intercept ability is limited to within 10-15 miles of the station or within 3 minutes of interception of the desired course. The best and most practical use the "NAV INTERCEPT" mode is course changing after passing after passing a VOR station. Another is capturing the localizer inbound. Once the new course is captured the "NAV TRACK" mode should be utilized since it contains cross-wind correction circuitry. Localizer intercept ability outbound on front or backcourse may be marginal.

Nav Tracking (VOR/LOC)

On autopilot control head :

1. "PULL TURN" knob - Pull out and leave in detent position.
2. "NAV 1 or 2" receiver switch - Select receiver providing stable navigation signal from the desired station.

On VOR/LOC Indicator :

3. Set OBS to desired VOR course.

On Autopilot head :

4. "NAV TRACK" button - Push in.
5. "HI SENS" button - Push in when tracking localizer.
6. "BACK CRS" button - Push in when tracking localizer back course inbound (or front course outbound).

CAUTION

- With "BACK CRS" button pushed in, normal indications of CDI of selected receiver are reversed, even when the autopilot "A/P" switch is in the "OFF" position and regardless of frequency selected (whether VOR or LOC). Glide slope indication is not affected.
 - An amber light located on the upper, left hand portion of the instrument panel and labeled "VOR/LOC REVERSED" will illuminate when "BACK CRS" button is pushed in to indicate the course deviation indication is reversed.
7. "PULL-TURN" knob - Center in detent and push in when CDI is within circle (less than 1 dot) and aircraft heading is parallel to course selected (within ± 5).

CAUTION

If heading and course deviations increase when tracking the localizer close in, push NAV INT button when heading is parallel to course or turn autopilot "A/P" switch "OFF" and fly aircraft manually.

NOTE

Tracking ability may be marginal outbound on front or backcourse of localizer.

NAV-O-MATIC 300A AUTOMATIC PILOT

1. GENERAL

This is a one-axis (roll) autopilot with heading coupling capabilities. The major components of the autopilot are as follows :

- An automatic pilot control head including a computer amplifier.
- A roll actuator.
- A turn coordinator.
- A directional gyro.
- "1 LOC REVERSED" or "2 LOC REVERSED" indicator lights.
- Mechanical parts.

2. OPERATION LIMITATIONS

- (1) The automatic pilot must not be used for take-off and landing
- (2) Minimum operation altitude : 200 m-656 ft.

3. URGENCY PROCEDURES

- (1) Overpower the autopilot by actuating the manual flight controls
- (2) Switch off the autopilot by pushing the A/P switch in the "OFF" position.

4. NORMAL PROCEDURES

BEFORE TAKE-OFF AND LANDING

On the autopilot control head :

- (1) "A/P" switch - "OFF".
- (2) "BACK CRS" button - "OFF" position.
(See CAUTION note under "NAV intercept", page 6-1.58).

CLIMB, CRUISE, DESCENT

Basic Directional Stability

- (1) Level wings.

On autopilot control head :

- (2) "PULL TURN" control knob : PULL OUT and CENTER in detent.
- (3) "A/P" switch - "ON".

NOTE

A 2-second delay will occur before the autopilot will function as desired. During this period a slight left turn impulse may occur.

- (4) "ROLL TRIM" control - Adjust for zero turn.

Command Turns

On autopilot control head :

- (1) "PULL TURN" knob - Pull and rotate to give desired turn rate up to a maximum of a standard rate turn.
- (2) To resume level flight : return "PULL TURN" knob to center (detent) position.

Magnetic Heading Hold Function

- (1) Directional gyro "PUSH" button - SET to aircraft magnetic heading.
- (2) "PULL TURN" knob - PULL OUT and LEAVE in center detent position.
- (3) Directional gyro - SET "bug" to desired heading.
- (4) On autopilot control head : "HDG SEL" pushbutton - PUSH.
- (5) "PULL TURN" knob - PUSH IN. The aircraft will turn automatically toward the selected heading and will roll out and hold the heading.
- (6) On autopilot control head : "TRIM" knob - ADJUST as required to zero deviation between stabilized heading and selected heading.
- (7) To change heading, move heading bug to new heading. The aircraft will turn in the direction the bug was moved and will hold the new heading.
- (8) Check the directional gyro against the aircraft compass at 15-minute intervals and reset if necessary.

Nav Intercept (VOR/LOC)

On autopilot control head :

- (1) "PULL TURN" knob - Pull out and leave in center detent position.
- (2) "NAV 1 or 2" selector switch - Select VHF receiver providing stable VOR/LOC navigation signal.

On VOR indicator :

- (3) Receiver "OBS" - Set in desired VOR course, if tracking omni.

On directional gyro :

- (4) Heading cursor - SET to selected VOR course or for localizer, set to inbound or outbound course.
- (5) Directional gyro - SET to aircraft magnetic heading.

On autopilot control head :

- (6) "NAV CAPT" button - PUSH IN.
- (7) "HI SENS" button - PUSH IN for localizer or VOR intercepts within 16 km (10 miles - 9 NM) of station. At greater distances, disengage the "HI SENS" button.
- (8) "BACK CRS" button - PUSH IN if intercepting localizer front course outbound or back course inbound.

CAUTION

- With "BACK CRS" button pushed in and a localizer frequency set on the selected receiver, normal indications for the CDI are reversed even when the autopilot "ON-OFF" switch is in the "OFF" position. Glideslope indications are not affected.
 - An amber light-located on the left hand portion of the instrument panel and labeled "LOC REVERSED" will illuminate when "BACK CRS" button is pushed in to indicate the course deviation indicator is reversed.
- (9) "PULL TURN" knob - CENTER in detent and PUSH IN. The aircraft will normally turn to a $45^{\circ} \pm 10^{\circ}$ intercept angle and then gradually decrease the angle as the course centerline is approached.

NOTE

During "NAV INT" in a crosswind, observe that the CDI needle settles in a fully centered position. If it remains off center 2 dots or more the heading bug should be moved an extra 10° toward the needle.

- (10) "NAV TRK" button - PUSH when the CDI needle is within one dot and the airplane has turned to within 10° of the course heading. This mode activates crosswind correction circuits.
- (11) "HI SENS" button - DISENGAGE for omni tracking, but leave it engaged for localizer tracking.

NAV tracking (VOR/LOC)

On autopilot control head :

- (1) "PULL TURN" knob - PULL OUT and LEAVE in detent position.
- (2) "NAV 1 or 2" receiver switch - SELECT receiver providing stable navigation signal.

On VOR indicator :

- (3) Omni bearing selector "OBS" - SET VOR course if tracking omni.

On directional gyro :

- (4) Heading cursor - SET to VOR course selected. For localizer, set to inbound or outbound course, as required.
- (5) Directional gyro - SET to aircraft magnetic heading. For precise tracking reset directional gyro periodically as required to remove procession error.
- (6) "NAV TRK" button - PUSH IN.
- (7) "HI SENS" button - PUSH IN when tracking localizer.
- (8) "BACK CRS" button - PUSH IN when tracking localizer back course inbound or front course outbound.

CAUTION

- With "BACK CRS" button pushed in and a localizer frequency set on the selected receiver, normal indications for the CDI are reversed even when the autopilot "ON-OFF" switch is in the "OFF" position. Glideslope indications are not affected.
- An amber light located on the left hand portion of the instrument panel and labeled "LOC REVERSED" will illuminate when "BACK CRS" button is pushed in

to indicate the course deviation indicator is reversed.

- (9) "PULL TURN" button - PUSH IN when CDI is less than 1 dot and aircraft heading is within ± 10 degrees of course selected.

NOTE

If CDI remains steadily off center, adjust autopilot lateral "TRIM" control as required. If drift correction requirements exceed 25° adjust heading bug toward the needle in 10° increments until the track is established.

- (10) During a localizer final approach - Turn the autopilot switch "OFF" after the runway becomes visible and complete the approach manually.

C A A APPENDIX

HOT WEATHER OPERATION

Refer to the general warm temperature starting information under starter engine in Section 4 of this manual. Avoid prolonged engine operation on the ground and the maximum temperature at which cooling is certified is 37,8° C hot day.

No minimum air temperature has been established.

AUTHORIZED OPERATIONS

Refer to page 2-2 of this manual.
To be deleted.

